

Air Diffusion

Pressure Relief Flaps and Multi-Leaf Dampers

Models G-PRF, D-PRF and MLD

Features

- All aluminium construction
- Wall mounting pressure relief flap
- Duct mounting pressure relief flap
- Flanged multi-leaf damper



Air Diffusion

Contents

	Page
Introduction	Page 1
Model G-PRF	Page 2
Model D-PRF	Page 3
Model MLD	Page 4

Introduction

A functional range of aluminium dampers is available from AIR DIFFUSION, which includes the Model G-PRF wall mounting pressure relief flap, Model D-PRF duct mounting pressure relief flap and the Model MLD for air balancing.

Model G-PRF is designed with a grille style flange for vertical mounting only and is suitable for low velocity, low pressure applications. The Model D-PRF incorporates a duct mounting flanged frame for either vertical or horizontal mounting and is suitable for low velocity, low pressure systems. For general or system air balancing purposes the Model MLD multi-leaf damper is offered with either opposed blade or parallel blade orientation.

Each damper is constructed from aluminium extrusions and aluminium sections with nylon bushes and neoprene seals fitted to the pressure relief flaps.

Both models of pressure relief flaps may have additional weights fitted to the blades whilst the Model D-PRF is also available with linked blades to provide a uniform operation.

Model MLD is obtainable with either simple manual control or fitted with a proprietary actuator for motorised operation.

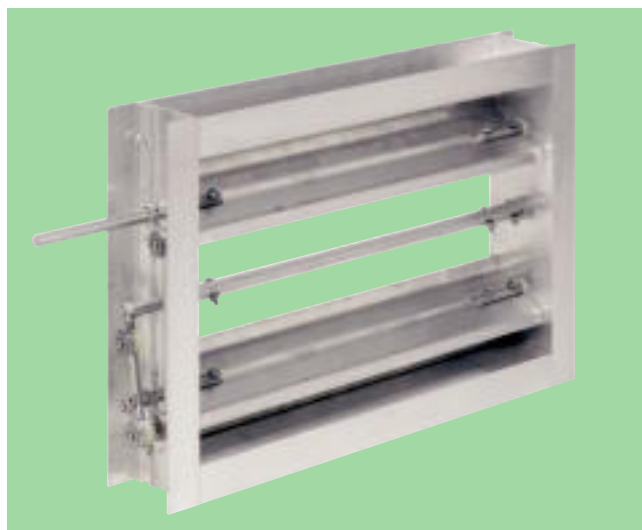

Model G-PRF

Description

Model G-PRF is suitable for use in low pressure, low velocity applications although only for vertical mounting. Blades are fitted with free running nylon bushes to operate at minimum pressure. Each blade is also fitted with neoprene edge seals. A matching flange and adjustable blade weights are available on request. Minimum size is 100mm x 100mm and maximum single section is 1800mm x 1200mm. (Note a mullion is fitted after 650mm and 1000mm in width).



Dimensions and Airflow Direction

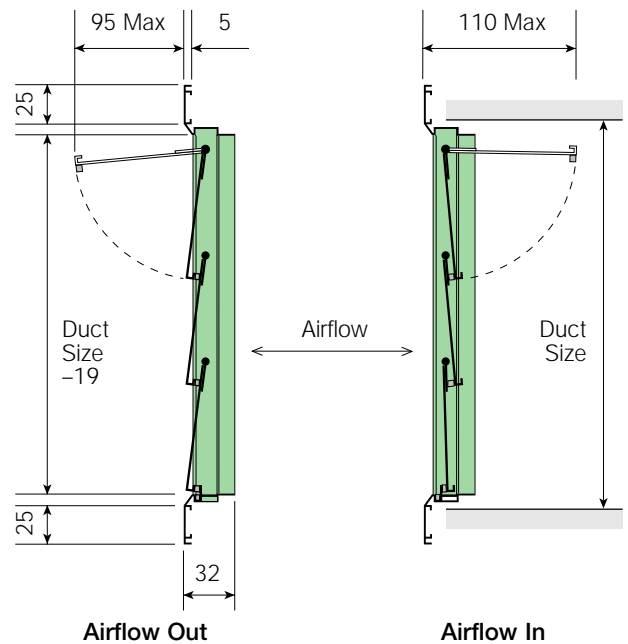
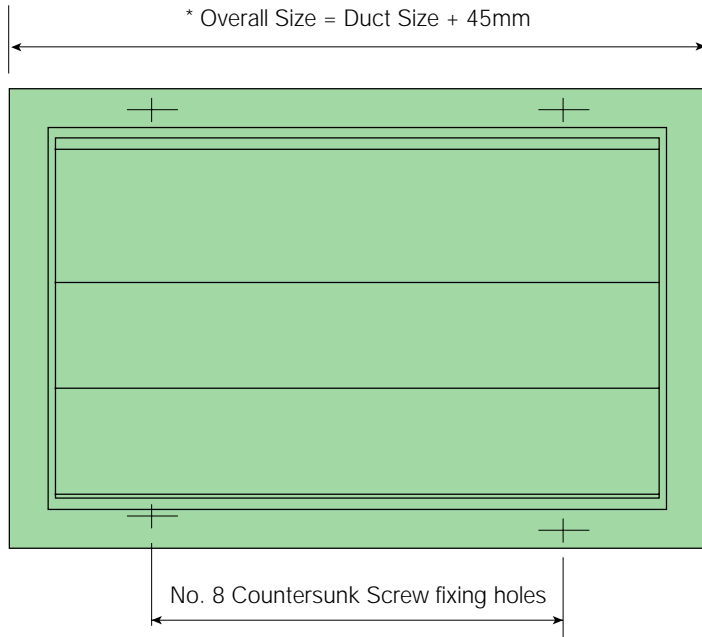

Blade Arrangement

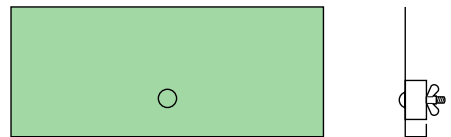

Optional Weights

Performance Guide

Duct Velocity m/s	0.5	1.0	1.5	2.0	2.5	3.0	3.5	4.0
Pressure n/m ²	7	12	17	21	24	28	32	37

How to Order

Example

Flange Style 25C	Model Type G-PRF	Fixing F1	Operation I	Finish 0	Control O
---------------------	---------------------	--------------	----------------	-------------	--------------

25C – 25mm Grille Flange (Standard Model G-PRF)

G-PRF – Grille Air Pressure Relief Flap

F1 – Countersunk Screw Holes in Flange. Standard

O – Airflow OUT
I – Airflow IN
Please specify airflow direction when ordering

0 – Mill Finish Aluminium Blades and Frame. Standard

O – Plain Blades. Standard

W – Weighted Blades

*If overall dimensions are critical, these must be stated on order.

Model D-PRF

Description

Model D-PRF is suitable for use in low pressure, low velocity applications and may be mounted vertically or horizontally. Blades are fitted with free running nylon bushes to operate at minimum pressure. Each blade is also fitted with neoprene edge seals, for uniform operation the blades can be linked, also adjustable blade weights can be added. A matching twin frame may also be provided to ensure the blades are not obstructed and open within the extended casing. Minimum

size is 150mm x 150mm and maximum single section is 2000mm x 2000mm, (note a mullion is fitted for sizes over 1000mm). Multiple assemblies are available.

Blade Arrangement

Mechanical stops prevent blades from fully opening to 90 degrees.

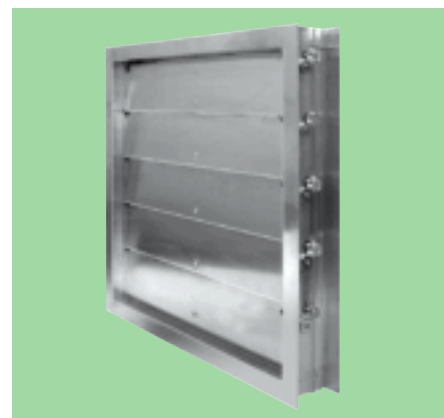

Dimensions and Airflow Direction

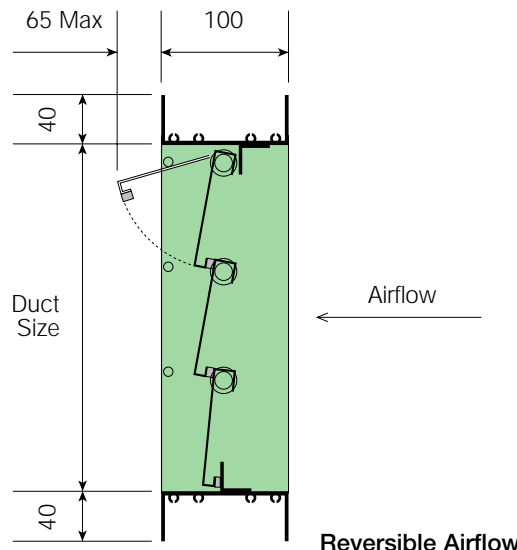
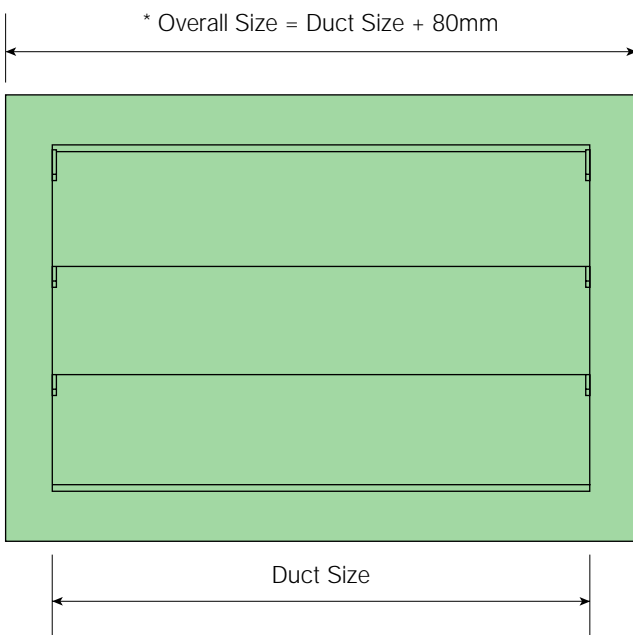

Performance Guide

Duct Velocity m/s	0.5	1.0	1.5	2.0	2.5	3.0	3.5	4.0
Pressure n/m ²	7	12	17	21	24	28	32	37

Blade Arrangement

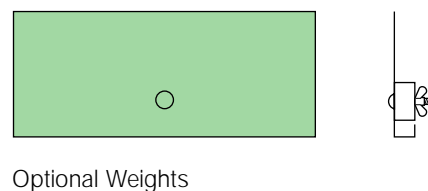

How to Order

Example

Flange Style F40	Model Type D-PRF	Fixing F0	Operation O	Finish 0	Control O
F40 – 40mm Flanged Frame	D-PRF – Duct Air Pressure Relief Flap	F0 – No Fixing. Standard F1 – Countersunk Screw Holes in Flange. Non standard	O – Airflow OUT TF – Extra Twin Frame (For Blade Fully Open Operation, within Casing) Please state separately on order if required.	0 – Mill Finish Aluminium Blades and Frame	O – Standard (Plain Blades) W – Weighted Blades L – Linked Blades W/L – Weighted & Linked Blades

*If overall dimensions are critical, these must be stated on order.

Model MLD

Description

Model MLD is designed for use in system air balancing or for normal air control (i.e. fitted behind external weather louvres). The damper is of an all aluminium construction with blades in free running nylon bushes and using plated screws. Two blade formats are available either opposed blade or parallel blade. Both blade configurations when fully open are contained within the flange casing depth. As standard each damper is provided with an extended spindle suitable for motorisation, alternatively a

manual operating lever can be supplied. Each damper is supplied as standard with a 40mm wide un-drilled flange. Minimum size is 200 x 200mm and maximum size is 2000 x 2000mm (note a mullion is fitted to sizes over 1000mm). Multiple assemblies are available.



Dimensions and Blade Arrangement

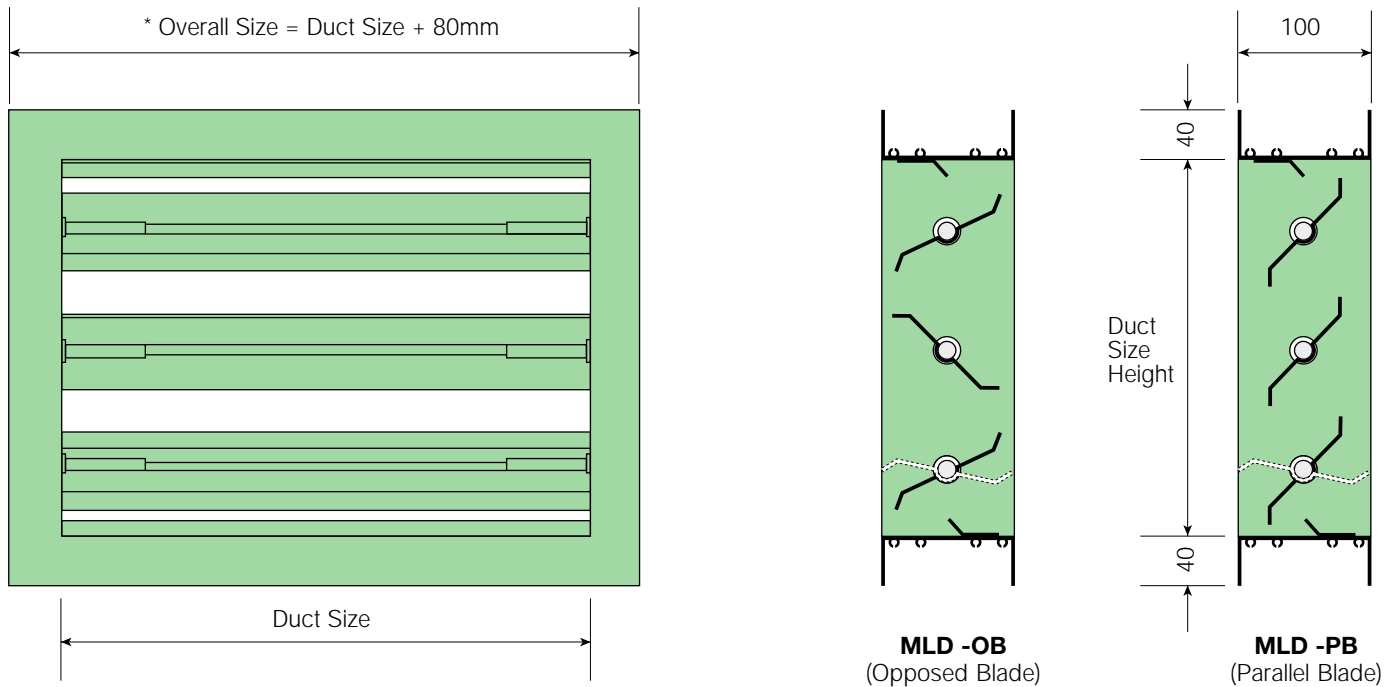

How to Order

Example

Flange Style F40	Model Type MLD	Fixing FO	Operation OB	Finish 0	Control E
F40 – 40mm Flanged Frame	MLD – Air Balancing Damper	FO – Plain Flange. Standard F1 – Counter Sunk. Screw holes in flange. Non Standard	OB – Opposed Blade Movement PB – Parallel Blade Movement	0 – Mill Finish Aluminium Blades and Frame	E – Extended Spindle for motorisation by others. Standard LD – Locking Device OL – Operating Lever MP – Motor Platform ML – Motor Lever and Factory Fitted Motor (please state type, voltage and operation separately)

*If overall dimensions are critical, these must be stated on order.

Air Diffusion Product Range



- Swirl, Displacement and High Induction Diffusers
- Perforated and Louvre Face Ceiling Diffusers
- Slot and Fixed Blade Linear Diffusers
- Cylinder and Jet Nozzle Diffusers
- Circular Diffusers and Air Valves
- Floor Bar Grilles
- Grilles
- External Louvres

Air Diffusion

CREATIVE AIR SOLUTIONS

Telephone 0845 095 1212 Facsimile: (01707) 294170
International Code: +441707 Email: sales@air-diffusion.co.uk Website: www.air-diffusion.co.uk

Part of Ruskin Air Management Limited

