

Wall and Ceiling Grille

Models CB, SD, DD, EC, PG, G45,
NVG, NB, GN, WB and GW

Features

- Curved Blade
- Single and Double Deflection
- Fixed and Removable Core Eggcrate
- Perforated Grille
- 45° Fixed Blade
- Non Vision
- Bar Grilles
- Welded Frame Construction
- Optional Opposed Blade Damper



Air Diffusion

Grilles Diffusers Louvres Chilled Beams

Ruskin Air Management Limited
www.ruskinuk.co.uk

Contents

	Page
Introduction	Page 3
Model CB Curved Blade Ceiling Grille	Pages 4 – 7
Model SD Single Deflection Grille and Model DD Double Deflection Grille	Pages 8 – 15
Model EC Egg Crate Grille	Pages 16 – 19
Model PG Perforated Grille	Page 20
Model G45 45° Fixed Blade Grille	Pages 21 – 23
Model NVG Non Vision Grille	Pages 24 – 25
Model NB Narrow Blade Bar Grille	Page 26
Model GN Narrow Blade Bar Grille	Page 27
Model WB Wide Blade Bar Grille	Page 28
Model GW Wide Blade Bar Grille	Page 29
Models NB, GN, WB and GW Dimensions	Pages 30 – 32
Performance Guide	Pages 33 – 36
Installation Guide	Pages 37 – 38
Ordering Information	Page 39
Product Range	Pages 40 – 41

Introduction

Having successfully manufactured grilles, registers and diffusers since 1972, **Air Diffusion** has the product to satisfy almost every wall or ceiling grille application used in conventional air distribution or ventilation systems. The comprehensive range can be used in both supply or extract systems and includes curved blade ceiling mounted grilles, single and double deflection grilles, egg crate grilles, perforated core grilles, fixed blade grilles, non vision grilles, and narrow or wide blade bar grilles.



Model CB4
Curved Blade Ceiling Grille

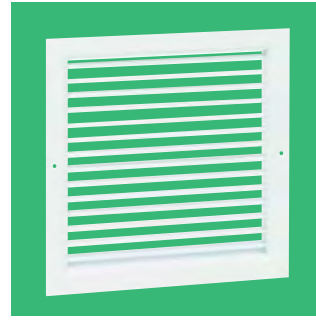

Model SD
Single Deflection Grille

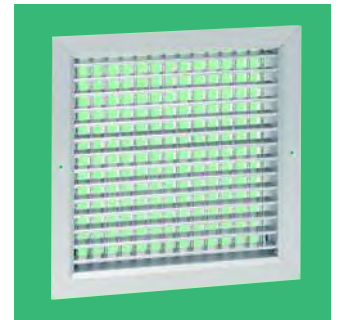

Model DD
Double Deflection Grille

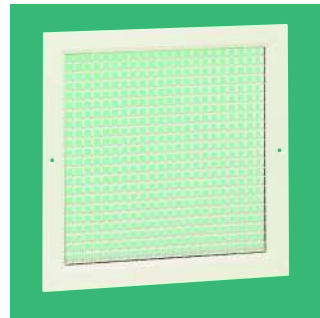

Model EC
Egg Crate Grille



Model PG
Perforated Grille



Model G45
45° Fixed Blade Grille



Model NVG
Non Vision Grille

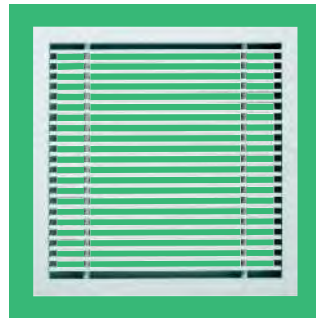

Model NB
Narrow Blade Bar Grille

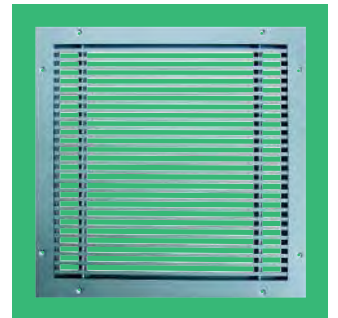

Model WB
Wide Blade Bar Grille

Model CB Curved Blade Ceiling Grille

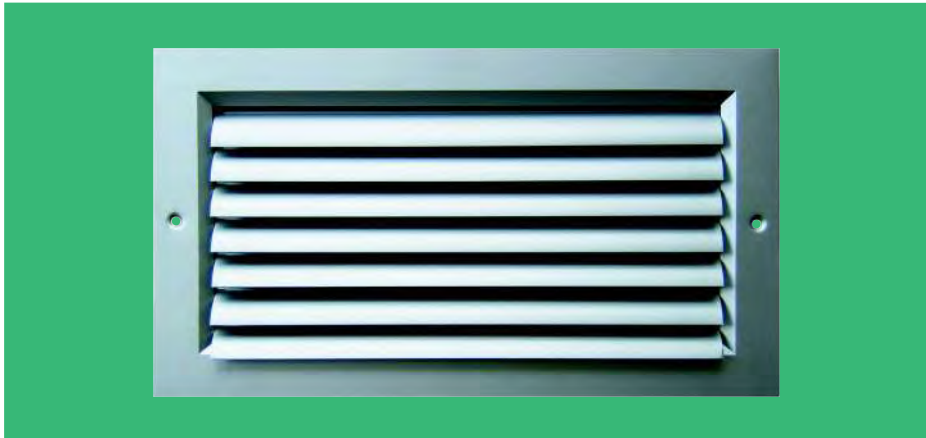

Model CB1 - No. 2 Finish



Model CB2 - No. 3 Finish



Model CB4 - No. 3 Finish

Description

Model CB curved blade ceiling grille incorporates individually adjustable blades to alter the angle of discharge. The grille can provide 1 way, 2 way, 3 way or 4 way air patterns. The grille is suitable for soffit or ceiling mounting and may be used for supply or extract applications. Typical installations include offices, shops, hotels, colleges, universities, hospitals and most commercial or industrial buildings.

Available as standard in white polyester powder coat finish. Other polyester powder coat finishes are also available as an option.

Standard fixing is with No.8 countersunk headed screws (BY OTHERS) using prepared countersunk screw holes in flange.

An optional opposed blade damper can be fitted to the rear of the grille and adjusted through the grille core.

Specification

Material

Extruded aluminium sections

Construction

25mm wide flange frame with corners mitred and welded. Adjustable blades are fixed to the frame using starlock washers and securing wire.

Installation Methods

F0 – No fixing (fixing BY OTHERS).

F1– Countersunk Screw Holes in Flange (Standard).

F4 – Rear strap (concealed behind grille core) mating strap BY OTHERS.

F6 – Rear strap and Mating “U” bracket (requires hemmed duct BY OTHERS)

For Installation Guide see Pages 37 / 38.

Accessories

Available fitted with opposed blade damper adjusted through the grille core.

Finish

0 – Mill extruded aluminium.

2 – Silver (RAL9006) polyester powder coat.

3 – White (RAL9010) 20% polyester powder coat. (Standard).

4 – Black (RAL9005) polyester powder coat.

6 – Special polyester powder coat.

(Please state separately the RAL colour reference and finish type required).

Model Types

Model CB1LG is supplied as a grille only having a 1 way air pattern with blades running parallel to the longest side.

Model CB1SG is supplied as a grille only having a 1 way air pattern with blades running parallel to the shortest side.



Model OBD

Model CB2LG is supplied as a grille only having a 2 way air pattern with blades running parallel to the longest side.

Model CB2SG is supplied as a grille only having a 2 way air pattern with blades running parallel to the shortest side.

Model CB2SG (LH) is supplied as a grille only having a 2 way corner air pattern with 1 set of blades running parallel to the shortest side and 1 set at right angles left handed.

Model CB2SG (RH) is supplied as a grille only having a 2 way corner air pattern with 1 set of blades running parallel to the shortest side and 1 set at right angles right handed.

Model CB3LG is supplied as a grille only having a 3 way air pattern with outer blades running parallel to the longest side.

Model CB3SG is supplied as a grille only having a 3 way air pattern with outer blades running parallel to the shortest side.

Model CB3SG (EQ) is supplied as a grille only having a 3 way air pattern with the 2 outer blade sets running parallel to the shortest side with an equal size 3rd set located in the centre.

Model CB4LG is supplied as a grille only having a 4 way air pattern with outer blades running parallel to the longest side.

Model CB4SG is supplied as a grille only having a 4 way air pattern with outer blades running parallel to the shortest side.

If an opposed blade damper is required the code reference letter G is replaced by R to denote that a damper is to be fitted. (e.g. CB4SR = 4 way air pattern with outer blades running parallel to the shortest side, fitted with an OBD).

Dimensions

Minimum size, subject to air pattern, is 100mm x 100mm up to a maximum single section of 1000mm x 1000mm. Special sizes also available.

Wall and Ceiling Grilles

Model CB Air Patterns

1 way discharge

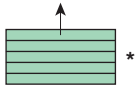

L - C B1

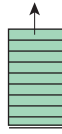

S - C B1

* Minimum dimension 100mm

2 way discharge

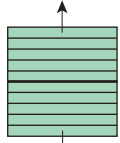

L - C B2 (Opp.)

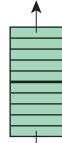

S - C B2 (Opp.)

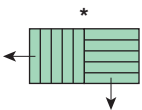

S - C B2 (LH)

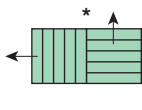

S - C B2 (RH)

* Minimum dimension 245mm for equal sections

3 way discharge - standard

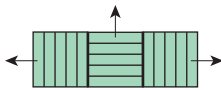

L - C B3 (EQ)

3 way discharge - options

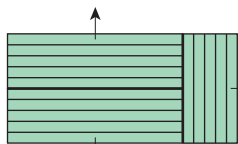

L - C B3

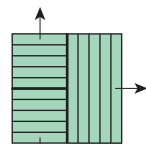

S - C B3

* Minimum dimension 295mm

4 way discharge

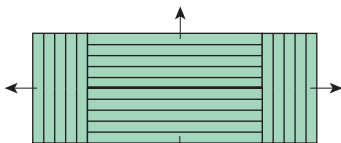

S - C B4

4 way discharge

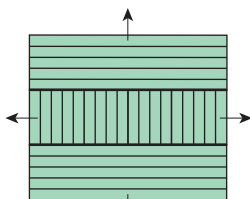

L - C B4

Dimensions

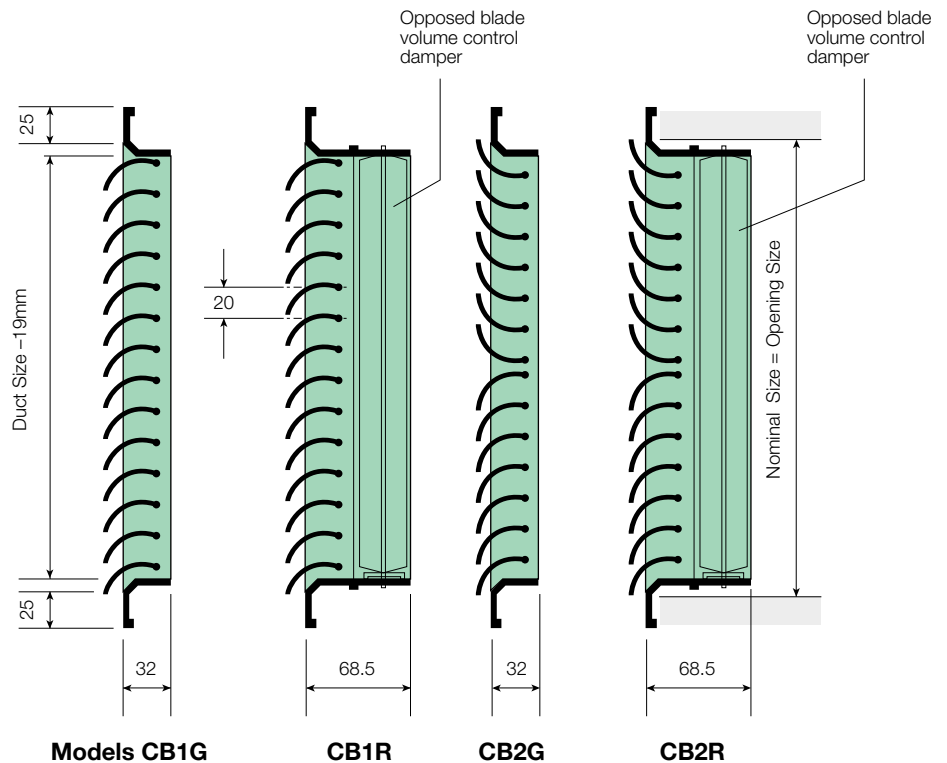
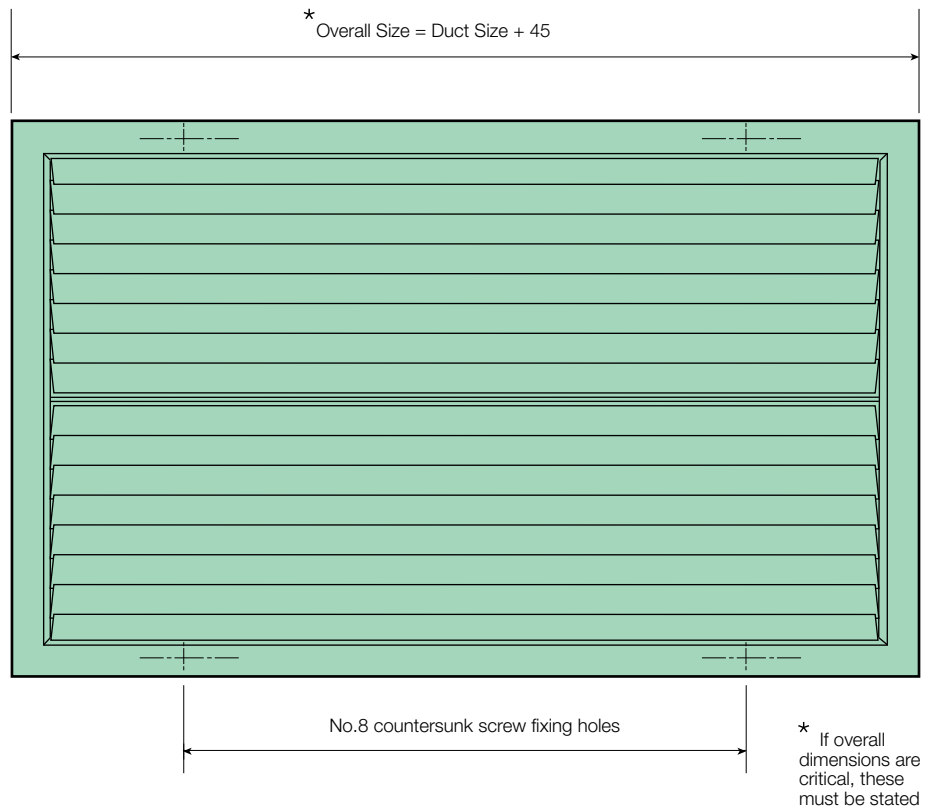

Model CB 1 Way and 2 Way Curved Blade Ceiling Grille

Performance

Models CB1/CB1R, CB2/CB2R
Nomogram

Maximum recommended air volume for free space cooling application

Ceiling height m.	2.4	2.75	3.0	3.7	4.5	6.0
Volume 1 Way L/S	80	125	200	300	450	950
Volume 2 Way L/S	160	250	400	600	900	1900

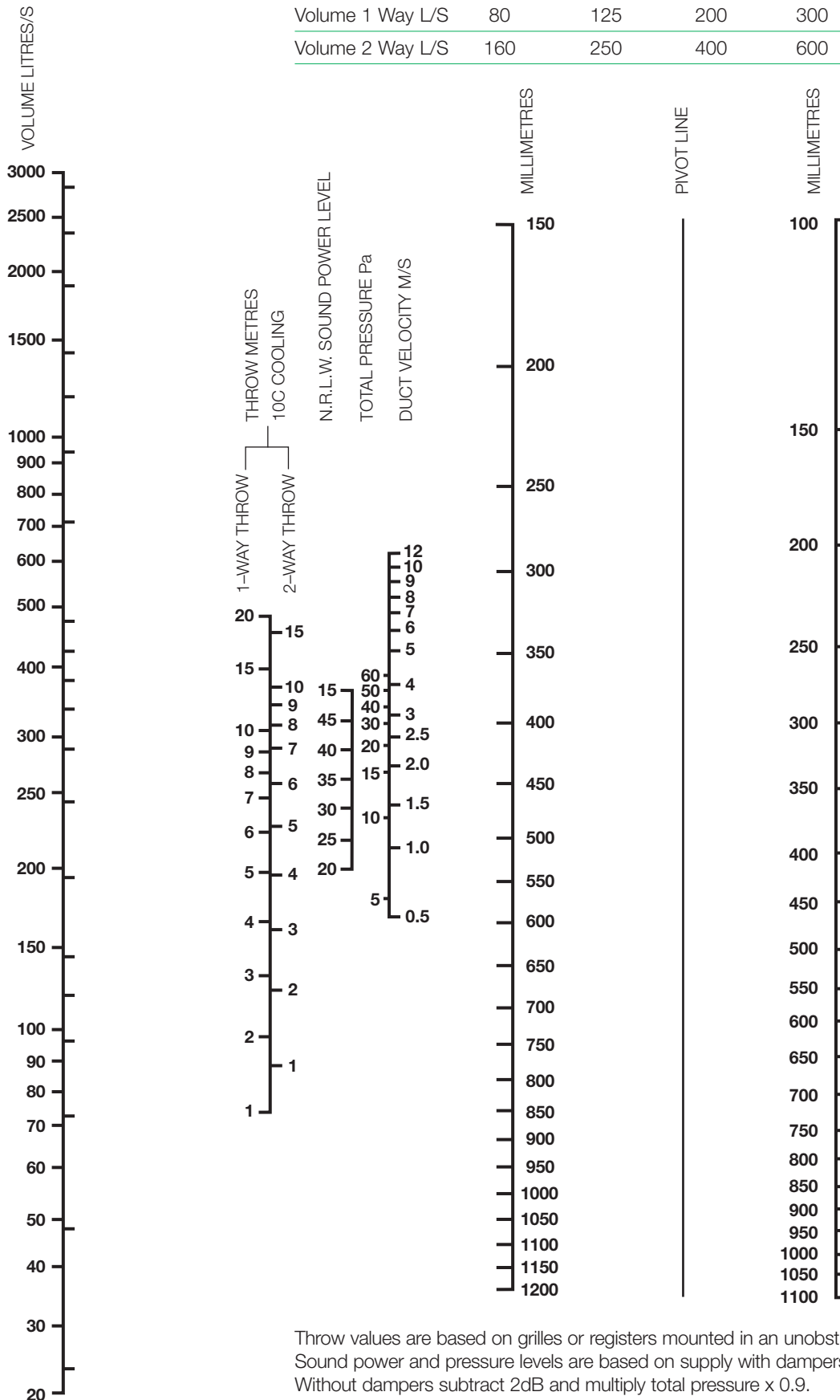

Throw values are based on grilles or registers mounted in an unobstructed ceiling application.
 Sound power and pressure levels are based on supply with dampers fully open.
 Without dampers subtract 2dB and multiply total pressure x 0.9.
 Sizes indicated are standard but all sizes are available.
 Throw values are based on 10° C cooling application. For Isothermal multiply x 1.25.

Model CB 3 Way and 4 Way Curved Blade Ceiling Grille

Performance

Models CB3/CB3R, CB4/CB4R
Nomogram

Maximum recommended air volume for free space cooling application

Ceiling height m.	2.4	2.75	3.0	3.7	4.5	6.0
Volume 3 Way L/S	240	375	600	900	1350	2850
Volume 4 Way L/S	320	500	800	1200	1800	3800

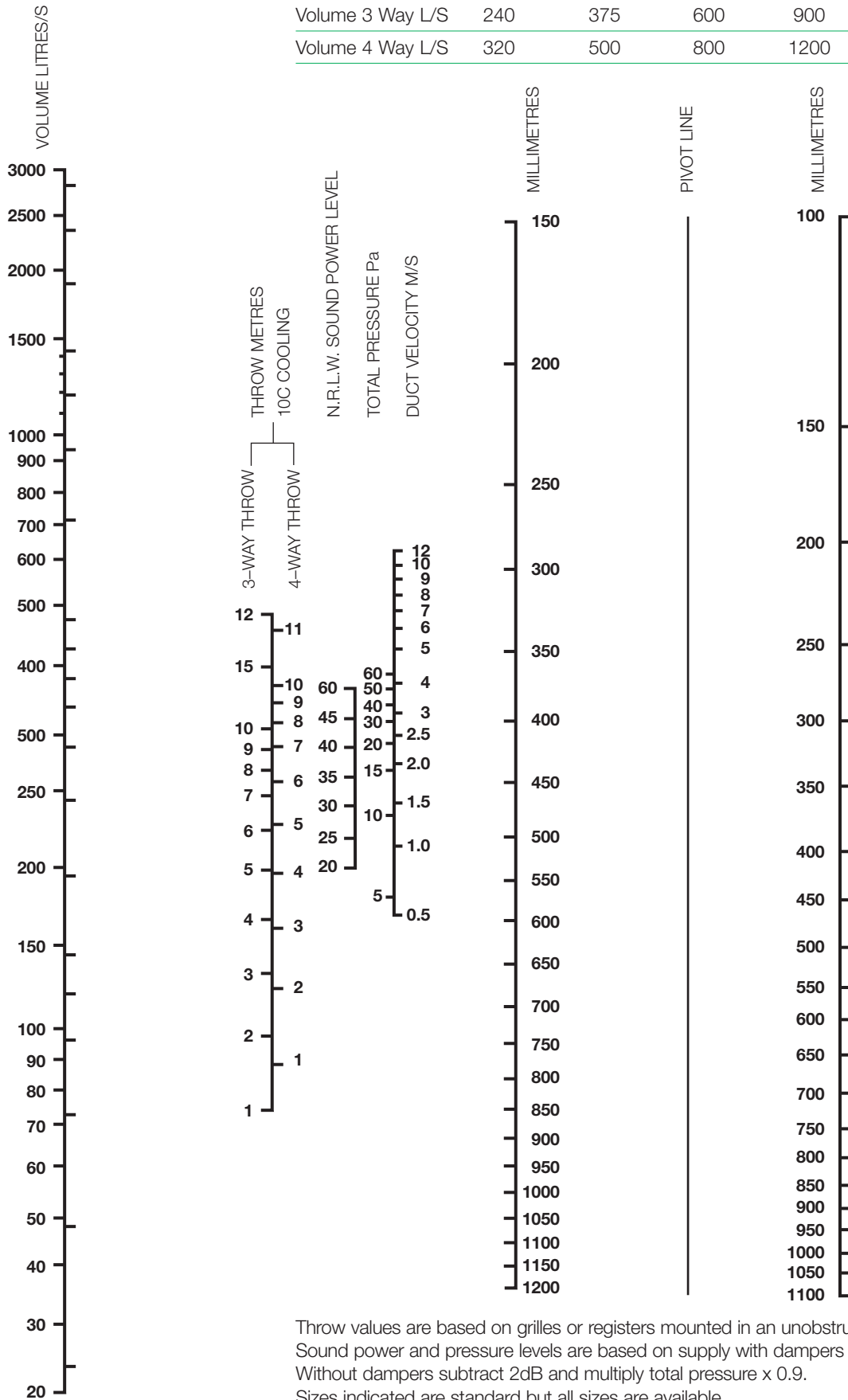

Throw values are based on grilles or registers mounted in an unobstructed ceiling application.
 Sound power and pressure levels are based on supply with dampers fully open.
 Without dampers subtract 2dB and multiply total pressure x 0.9.
 Sizes indicated are standard but all sizes are available.
 Throw values are based on 10° C cooling application. For Isothermal multiply x 1.25.

Model SD Single Deflection Grille



Model SD - No. 3 Finish



Model SD - No. 2 Finish



Model OBD

Description

Model SD single deflection grille incorporates a set of individually adjustable blades. The blades may be either horizontal or vertical. The grille is suitable for sidewall, soffit or cill mounting and may be used for supply or extract applications. Typical installations include offices, shops, hotels and most commercial or industrial buildings.

Available as standard in white polyester powder coat finish. Other polyester powder coat finishes are also available as an option.

Standard fixing is with No.8 countersunk headed screws (BY OTHERS) using prepared countersunk screw holes in flange.

An optional opposed blade damper can be fitted to the rear of the grille and adjusted through the grille core.

Specification

Material

Extruded aluminium sections

Construction

25mm wide flange frame with corners mitred and welded. Adjustable blades are 5mm wide, 21mm deep on a 20mm pitch and secured into the frame by starlock washers and securing wire.

Installation Methods

F0 – No fixing (fixing BY OTHERS).

F1– Countersunk Screw Holes in Flange (**Standard**).

F2 – Spring Clips (not recommended for ceiling or high sidewall installation).

F4 – Rear strap (concealed behind grille core) mating strap BY OTHERS.

F6 – Rear strap and Mating “U” bracket (requires hemmed duct BY OTHERS).

For Installation Guide see Page 37/38.

Accessories

Available fitted with opposed blade damper adjusted through the grille core.

Finish

0 – Mill extruded aluminium.

2 – Silver (RAL9006) polyester powder coat.

3 – White (RAL9010) 20% polyester powder coat (**Standard**).

4 – Black (RAL9005) polyester powder coat.

6 – Special polyester powder coat finish. (Please state separately the RAL colour reference and finish type required).

Model Types

Model SDHG is supplied as a grille only with a single set of horizontal blades, along longest side.

Model SDVG is supplied as a grille only with a single set of vertical blades, along longest side.

Model SDHR is supplied as a grille having a single set of horizontal blades, along longest side and fitted with an OBD.

Model SDVR is supplied as a grille having a single set of vertical blades, along longest side, and fitted with an OBD.

Dimensions

Minimum size is 100mm x 100mm up to a maximum single section of 1000mm x 1000mm. Special sizes also available.

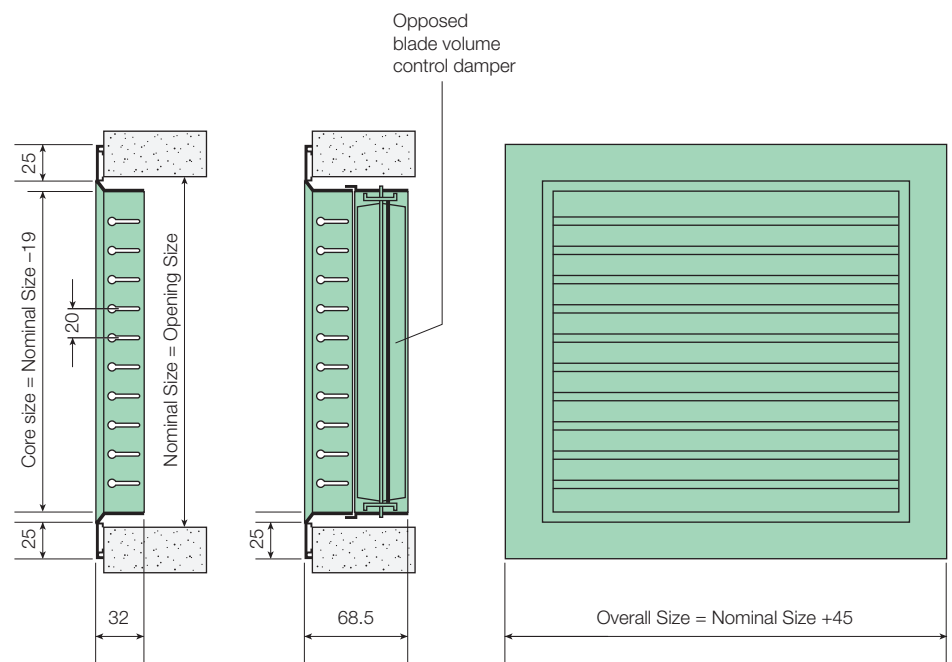

Model DD Double Deflection Grille

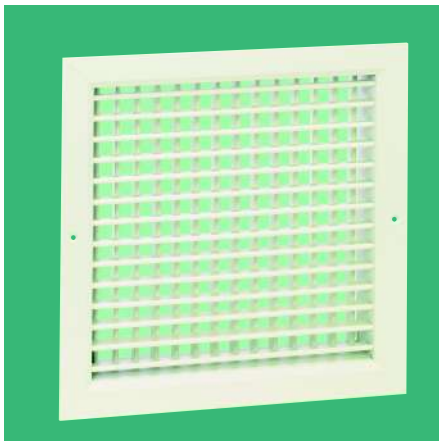

Model DD - No. 3 Finish

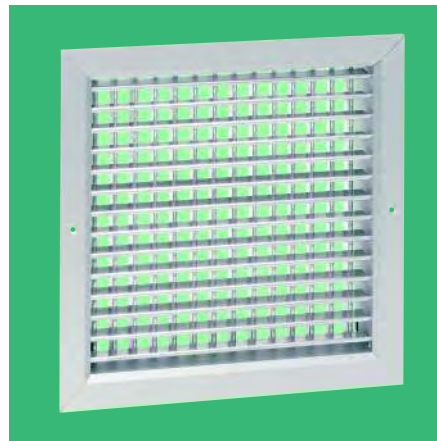

Model DD - No. 2 Finish



Model OBD

Description

Model DD double deflection grille incorporates two sets of individually adjustable blades. The front blades may be either horizontal or vertical. The grille is suitable for sidewall, soffit or cill mounting and may be used for supply or extract applications. Typical installations include offices, shops, hotels and most commercial or industrial buildings.

Available as standard in white polyester powder coat finish. Other polyester powder coat finishes are also available as an option.

Standard fixing is with No.8 countersunk headed screws (BY OTHERS) using prepared countersunk screw holes in flange.

An optional opposed blade damper can be fitted to the rear of the grille and adjusted through the grille core.

Specification

Material

Extruded aluminium sections

Construction

25mm wide flange frame with corners mitred and welded. Adjustable blades are 5mm wide, 21mm deep on a 20mm pitch and secured into the frame by starlock washers and securing wire.

Installation Methods

F0 – No fixing (fixing BY OTHERS).

F1– Countersunk Screw Holes in Flange (**Standard**).

F2 – Spring Clips (not recommended for ceiling or high sidewall installation).

F4 – Rear strap (concealed behind grille core) mating strap BY OTHERS.

F6 – Rear strap and Mating “U” bracket (requires hemmed duct BY OTHERS).

For Installation Guide see Page 37/38.

Accessories

Available fitted with opposed blade damper adjusted through the grille core.

Finish

0 – Mill extruded aluminium.

2 – Silver (RAL9006) polyester powder coat.

3 – White (RAL9010) 20% polyester powder coat finish (**Standard**).

4 – Black (RAL9005) polyester powder coat.

6 – Special polyester powder coat finish (Please state separately the RAL colour reference and finish type required).

Model Types

Model DDHG is supplied as a grille only with one set of front horizontal and one set of rear vertical blades.

Model DDVG is supplied as a grille only with one set of front vertical and one set of rear horizontal blades.

Model DDHR is supplied as a grille having one set of front horizontal and one set of rear vertical blades and fitted with an OBD.

Model DDVR is supplied as a grille having one set of front vertical blades and one set of rear horizontal blades and fitted with an OBD.

Dimensions

Minimum size is 100mm x 100mm up to a maximum single section of 1000mm x 1000mm. Special sizes also available.

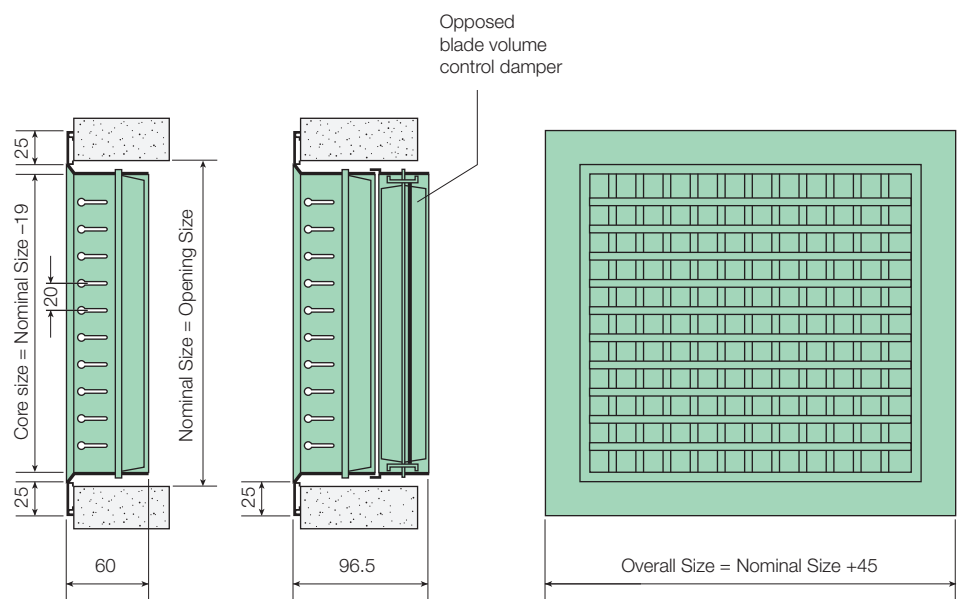

Model SD Single Deflection Grille and Model DD Double Deflection Grille

Model SD and DD Selection procedure

1. Determine air volume flow rate per outlet.
2. If a supply application, establish available throw – use SD/DD selection nomogram.
3. Establish required maximum noise and pressure values – for exhaust use SD/DD selection nomogram.
4. With a straight edge line across from the litres per second value through values within the maximum parameters established to the pivot line.
5. Retaining the position of intersection at the pivot line, pivot the straight edge until it meets acceptable values of size to its left and right.

Note:
The pivot line represents an area and by maintaining position on this line widths and heights can be selected of equal area. See note regarding effect of aspect ratio on throw for supply application.

Vertical discharging airstreams are affected by temperature and the resulting density difference between the discharging air and ambient air. Throw is also affected by the proximity of surfaces. Use the graph above to provide a correction factor to apply to catalogue throws.

Note: The relative temperature values are based on downward discharge – for upward discharge reverse the heating and cooling effect.

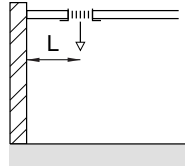

Curve Reference

X	L = Up to 0.5m
Y	L = More than 2.0m

The effect of temperature on vertical discharge

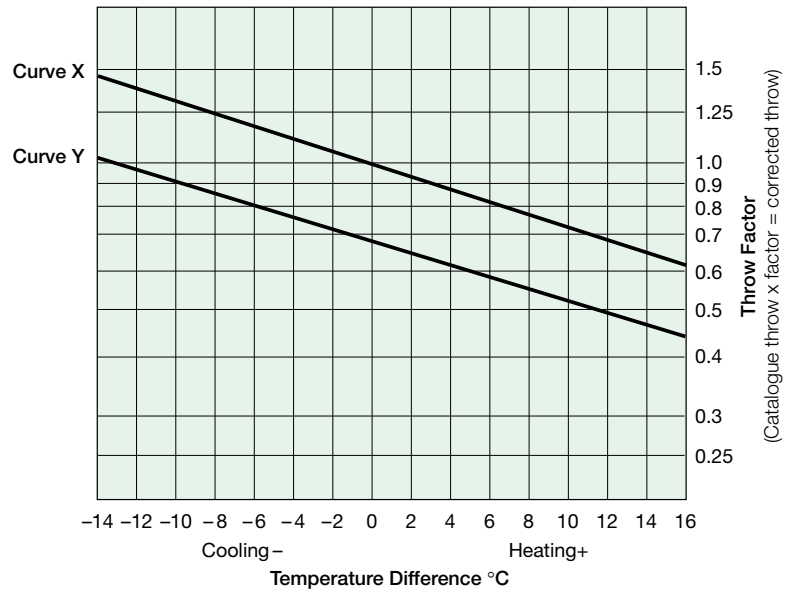

SDH Maximum Free Area – Blades at 0°

Grille Height	Grille Width															
	150	200	250	300	350	400	450	500	550	600	700	800	900	1000	1100	1200
100	.0084	.0117	.0150	.0182	.0215	.0247	.0280	.0312	.0344	.0377	.0442	.0507	.0572	.0637	.0702	.0767
150	.0133	.0185	.0236	.0287	.0338	.0390	.0441	.0492	.0543	.0595	.0697	.0799	.0902	.1005	.1107	.1210
200	.0182	.0252	.0322	.0392	.0462	.0532	.0602	.0672	.0742	.0812	.0952	.1092	.1232	.1372	.1512	.1652
250	.0231	.0320	.0408	.0497	.0586	.0675	.0763	.0852	.0941	.1030	.1207	.1385	.1562	.1740	.1917	.2095
300	.0280	.0387	.0494	.0602	.0710	.0817	.0925	.1032	.1140	.1247	.1462	.1677	.1892	.2107	.2322	.2537
350	.0328	.0455	.0581	.0707	.0833	.0959	.1086	.1212	.1338	.1465	.1717	.1970	.2222	.2475	.2727	.2980
400	.0377	.0522	.0667	.0812	.0957	.1102	.1247	.1392	.1537	.1682	.1972	.2262	.2552	.2842	.3132	.3422
450	.0426	.0590	.0753	.0917	.1081	.1245	.1408	.1572	.1736	.1900	.2227	.2555	.2882	.3210	.3537	.3865
500	.0475	.0657	.0840	.1022	.1205	.1387	.1570	.1752	.1935	.2117	.2482	.2847	.3212	.3577	.3942	.4307
550	.0523	.0724	.0926	.1127	.1328	.1530	.1731	.1932	.2133	.2335	.2737	.3140	.3542	.3945	.4347	.4750
600	.0572	.0792	.1012	.1232	.1452	.1672	.1892	.2112	.2332	.2552	.2992	.3432	.3872	.4312	.4752	.5192

SDV Maximum Free Area – Blades at 0°

Grille Height	Grille Width															
	150	200	250	300	350	400	450	500	550	600	700	800	900	1000	1100	1200
100	.0082	.0112	.0142	.0172	.0202	.0232	.0262	.0292	.0322	.0352	.0412	.0472	.0532	.0592	.0652	.0712
150	.0133	.0182	.0231	.0280	.0328	.0377	.0426	.0475	.0523	.0572	.0670	.0767	.0865	.0962	.1060	.1157
200	.0185	.0252	.0320	.0387	.0455	.0522	.0590	.0657	.0724	.0792	.0927	.1062	.1197	.1332	.1467	.1602
250	.0236	.0322	.0408	.0494	.0581	.0667	.0753	.0840	.0926	.1012	.1185	.1357	.1530	.1702	.1858	.2047
300	.0287	.0392	.0497	.0602	.0707	.0812	.0917	.1022	.1127	.1232	.1442	.1652	.1862	.2072	.2282	.2492
350	.0338	.0462	.0586	.0710	.0833	.0957	.1081	.1205	.1328	.1452	.1700	.1947	.2195	.2442	.2690	.2937
400	.0390	.0532	.0675	.0817	.0959	.1102	.1245	.1387	.1530	.1672	.1957	.2242	.2527	.2812	.3097	.3382
450	.0441	.0602	.0763	.0925	.1086	.1247	.1408	.1570	.1731	.1892	.2215	.2537	.2860	.3182	.3505	.3827
500	.0492	.0672	.0852	.1032	.1212	.1392	.1572	.1752	.1932	.2112	.2472	.2832	.3192	.3552	.3912	.4272
550	.0543	.0742	.0941	.1140	.1338	.1537	.1736	.1935	.2133	.2332	.2730	.3127	.3525	.3922	.4319	.4717
600	.0595	.0812	.1030	.1247	.1465	.1682	.1900	.2117	.2335	.2552	.2987	.3422	.3857	.4292	.4727	.5162

Model SD Single Deflection Grille and Model DD Double Deflection Grille

Model SD and DD Selection Guide

Notes to selection data

Throw

Throws shown in the catalogue are based on horizontal discharge of cooled air with full attachment of the jet to a flat ceiling close enough above the grille position to enable this condition to occur. For most cases for ceiling effect the grille would be positioned no more than 300mm below the ceiling.

The catalogue gives figures for throw at 0° and 40° blade deflection being the full range of throw available. It is good practice to select for the required throw at the mid point of the range. In the example on SD/DD nomogram the selection is ideal for an available throw of 6.5m.

Throws given are the horizontal distance to a terminal velocity of 0.25m/s.

Drop

The effect of drop with ceiling effect and ceiling heights of 2.6 – 500 litres per second per outlet if correctly selected should not cause problems up to a cooling temperature differential of 10 °C.

Free Space Supply

In free space horizontal discharge applications the direction of the air will be dependant on the relative temperature of the primary air to ambient. This can cause unsatisfactory conditioning of occupied zone and in some cases vertical discharge down or up walls is a more suitable approach. (Please refer to the chart showing the effect of temperature and surface to vertical discharge – fig 1).

Throw is reduced in free space where there is no ceiling effect or other surface proximity and reduction for isothermal conditions is 30%

from the figures given on the nomogram.

For primary air above or below ambient the throw measured horizontally is effected by the mass and temperature – fig 3 illustrates typical centre of jet air patterns at the same mass and different temperatures.

Spread

The spread of air at different blade angles is given in fig 2. Spread can be used to establish fixing centres for multiple outlets. It should be considered that if spread is restricted by impingement of adjacent air streams or obstructions the effective spread will be reduced and the length of throw proportionately increased.

Aspect Ratio

From all the points above it is clear that throw is a complex derived value and another factor which has an effect is the aspect ratio or proportion of the largest nominal dimension to the smallest.

Nomogram figures can be taken for aspect ratios from 1:1 to 2:1 but if the aspect ratio is greater then the following factors can be applied.

- 3:1 Reduce throw by 5%
- 4:1 Reduce throw by 8%
- 5:1 Reduce throw by 12%

Pressure Loss

The total pressure losses given are for grilles and dampers fitted with the damper fully open and blades at 0°. For blades at 40° add 50% to pressure values given although a 10% reduction of the value can be taken for grilles without dampers.

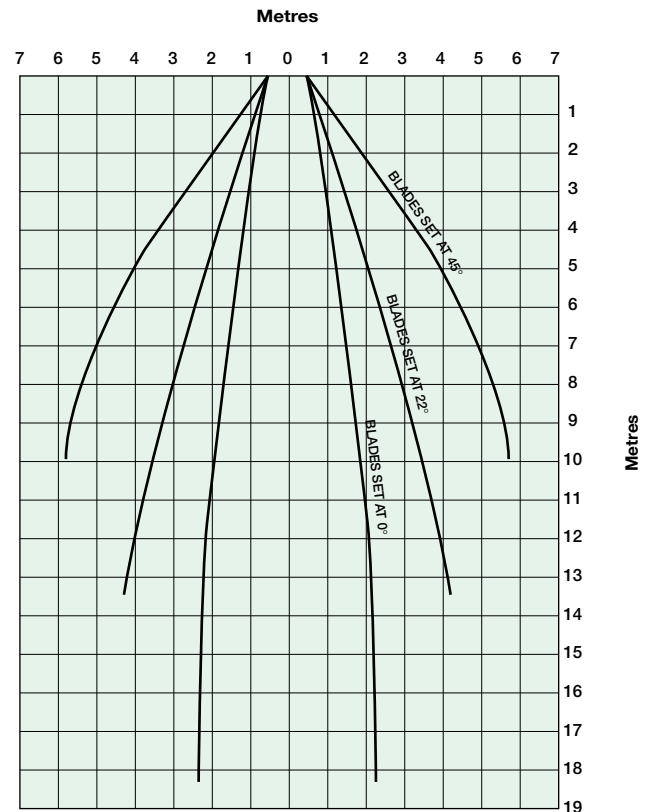

Spread characteristics of deflection grilles

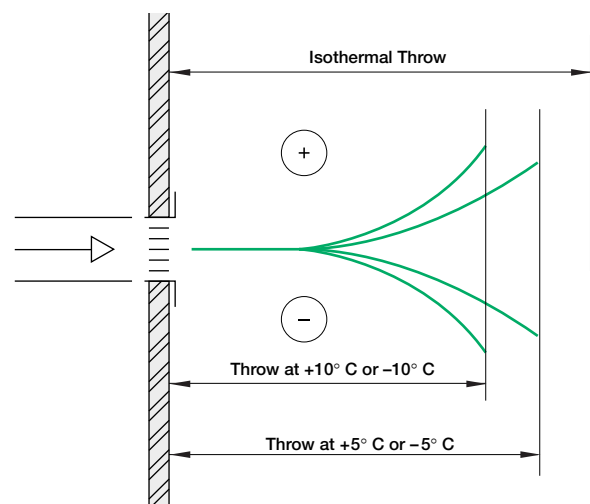

Sound Levels

Wherever possible we give NR power levels generated by the product. This enables the allowances for room characteristics, surface mounting and multiple outlets from the sound advice leaflet to be taken into account and more accurately predict the sound pressure measured in the occupied space.

The NR power level given for SD/DD series grilles includes for a fully open damper, for grilles without dampers 2dB can be subtracted, however, the effect of partly closing the damper for balancing purposes can add significantly to generated noise.

Model SD Single Deflection Grille - Nomogram

Sound power and pressure levels are based on supply with dampers fully open and blades at 0°. For 40° blade add 8dB. Please refer to selection procedure for details.

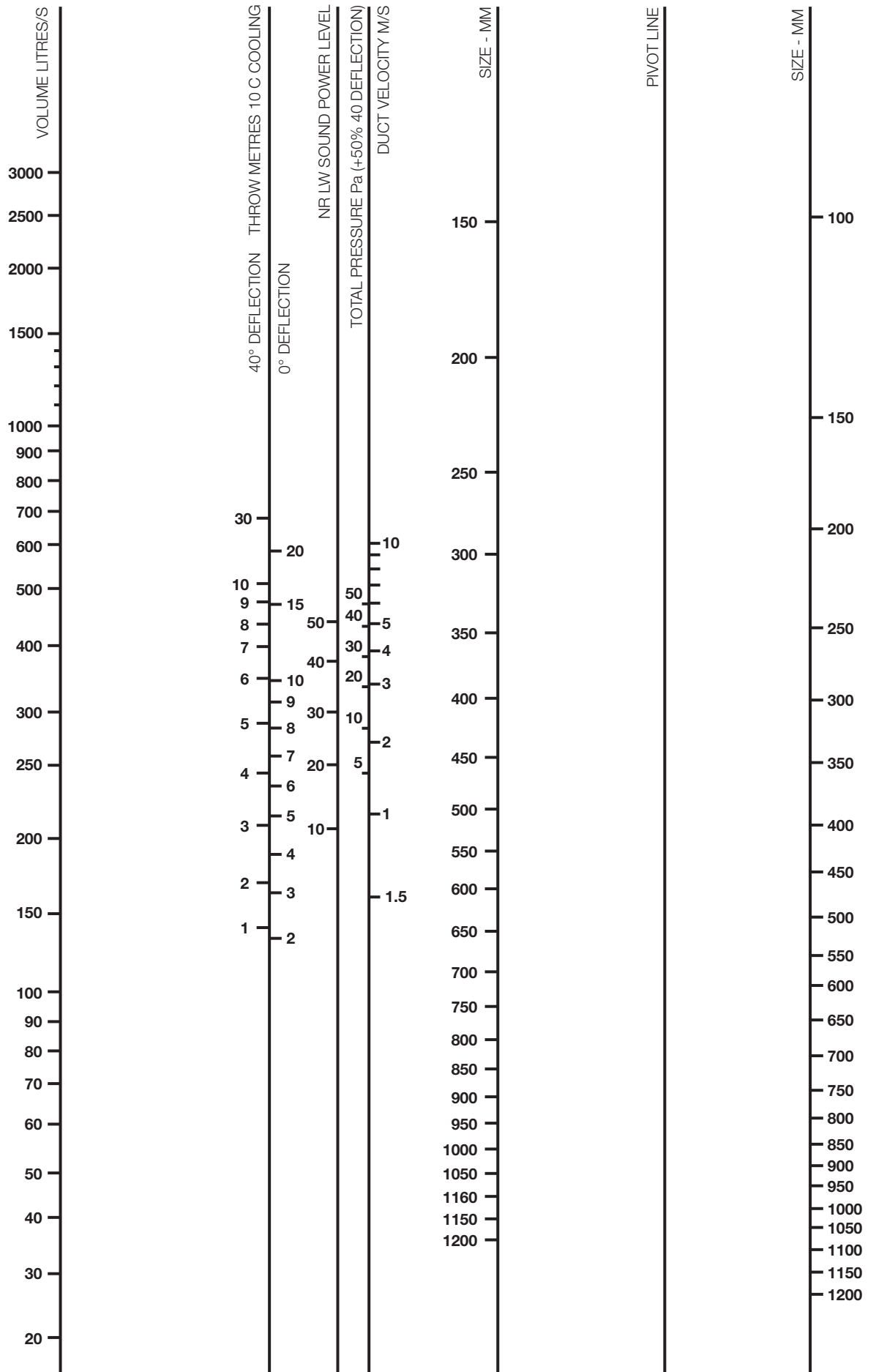

Model DD Double Deflection Grille - Nomogram

Sound power and pressure levels are based on supply with dampers fully open. Please refer to selection procedure for details.

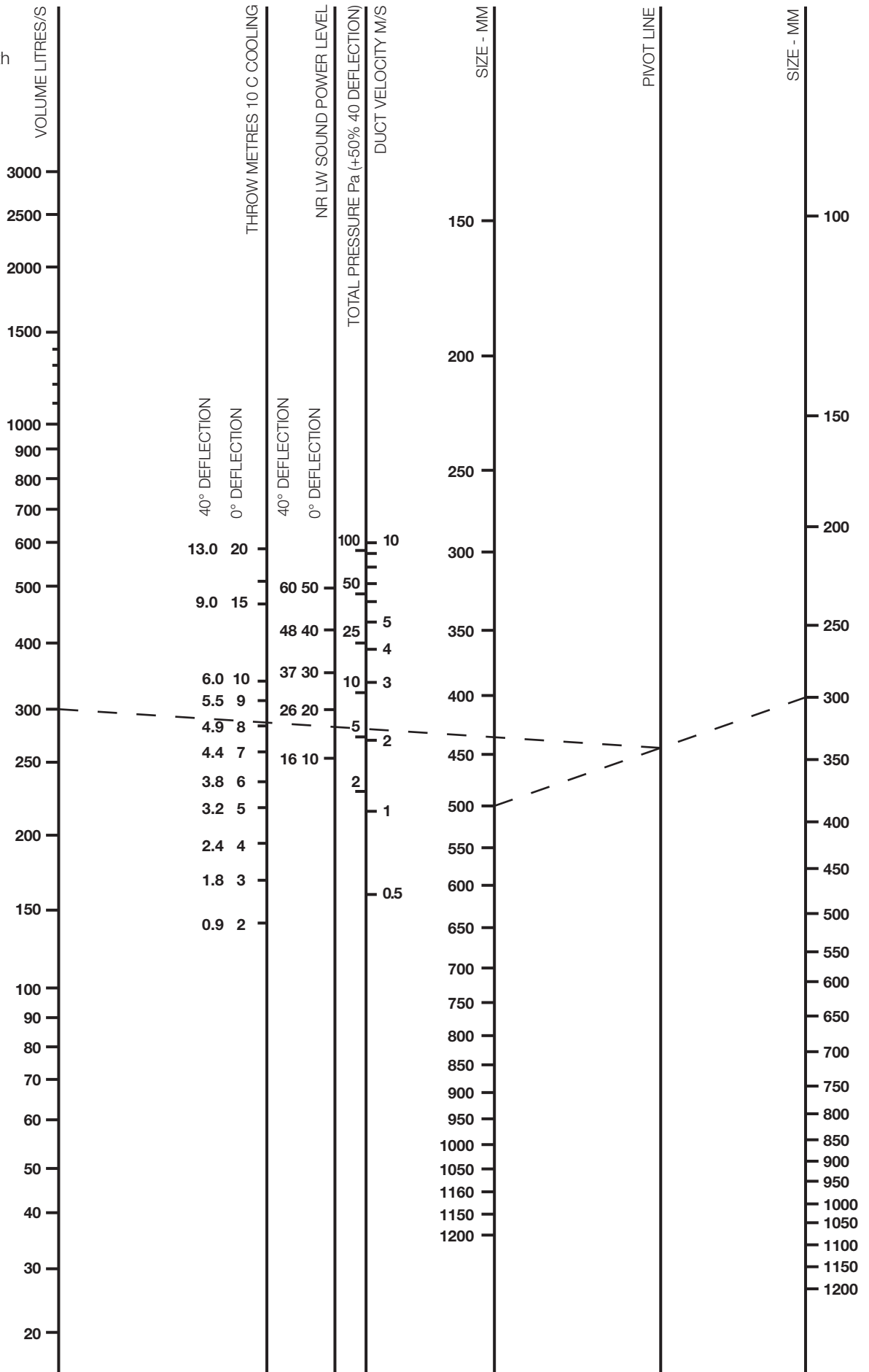

Quick Selection Performance Tables for Standard Sizes: Models SDHG - SDHR

Nominal Size w x h	Performance							
150 x 150	Air Volume	l/s	35	58	80	102	124	146
	Neck Velocity	m/s	2.0	3.2	4.5	5.8	7.0	8.2
	Noise Level	NR	–	18	28	35	41	46
	Pressure Loss	Pa	6	17	33	54	79	110
	Throw (0 deg)	m	3.2	5.1	7.3	8.2	9.2	9.8
200 x 200	Air Volume	l/s	63	102	141	181	220	259
	Neck Velocity	m/s	1.9	3.0	4.2	5.3	6.5	7.7
	Noise Level	NR	–	19	29	36	42	47
	Pressure Loss	Pa	6	15	28	46	69	95
	Throw (0 deg)	m	3.3	5.5	6.7	8.2	9.8	12.0
250 x 250	Air Volume	l/s	98	159	221	282	344	405
	Neck Velocity	m/s	1.8	2.9	4.0	5.1	6.3	7.4
	Noise Level	NR	–	20	29	37	43	48
	Pressure Loss	Pa	5	14	26	43	63	88
	Throw (0 deg)	M	4.5	6.3	8.5	11.5	13.2	14.3
300 x 300	Air Volume	l/s	141	230	318	407	495	584
	Neck Velocity	m/s	1.7	2.8	3.9	5.0	6.1	7.2
	Noise Level	NR	–	21	30	38	43	48
	Pressure Loss	Pa	5	13	25	40	60	83
	Throw (0 deg)	m	4.7	7.5	11.6	12.5	15.0	17.2
350 x 350	Air Volume	l/s	192	313	433	554	674	794
	Neck Velocity	m/s	1.7	2.8	3.8	4.9	6.0	7.0
	Noise Level	NR	–	21	31	38	44	49
	Pressure Loss	Pa	5	12	24	39	58	80
	Throw (0 deg)	m	5.6	9.0	12.2	14.1	17.2	19.1
400 x 400	Air Volume	l/s	251	408	566	723	880	
	Neck Velocity	m/s	1.7	2.7	3.8	4.8	5.9	
	Noise Level	NR	–	22	32	39	45	
	Pressure Loss	Pa	5	12	23	38	56	
	Throw (0 deg)	m	6.6	9.5	13.1	15.4	18.7	
450 x 450	Air Volume	l/s	318	517	716	915	1114	
	Neck Velocity	m/s	1.7	2.7	3.7	4.8	5.8	
	Noise Level	NR	–	23	33	40	46	
	Pressure Loss	Pa	4	12	23	37	55	
	Throw (0 deg)	m	7.4	11.2	13.7	17.3	20.0	

Performance Notes

Throw values are based on grilles or registers mounted in the sidewall not more than one metre below an unrestricted ceiling. For grilles located more than one metre below the ceiling, throw values should be reduced by approximately 25%.

Throw values are based on 10 °C cooling applications. For Isothermal throws multiply by 1.25.

Terminal Velocities are based on 0.25 m/s.

Each NR value represents the noise rating curve which will not be exceeded by the sound pressure in any of the octave bands, 125 Hz through to 4k Hz. Each NR value is based on a room absorption of 10 dB, re 10 watts. Each NR value is further based on register operating at a 0 degree deflection. Settings of 22.5 or 45 degree, increase the stated sound levels by 1 or 7 NR, respectively. A dash (-) in space indicates an NR value less than 10.

The NR level shown included for a grille with fully open obd fitted, a 2 dB reduction can be applied for grilles without an obd fitted. The effect of partly closing an obd for balancing purposes will significantly add to generated noise.

The pressure loss shown is for a grille with fully open obd fitted and the blades set for 0 degrees. For blades at 40 degrees a 50% addition should be applied. For grilles without an obd fitted a 10% reduction to the value shown can be applied.

For other performance or selection details please contact the sales office.

Quick Selection Performance Tables for Standard Sizes: Models DDHG - DDHR

Nominal Size w x h	Performance							
150 x 150	Air Volume	l/s	35	58	80	102	124	146
	Neck Velocity	m/s	2.0	3.2	4.5	5.8	7.0	8.2
	Noise Level	NR	–	18	28	35	41	46
	Pressure Loss	Pa	6	17	33	54	79	110
	Throw (0 deg)	m	2.0	3.8	5.3	6.7	7.8	8.6
200 x 200	Air Volume	l/s	63	102	141	181	220	
	Neck Velocity	m/s	1.9	3.0	4.2	5.3	6.5	
	Noise Level	NR	–	19	29	36	42	
	Pressure Loss	Pa	6	15	28	46	69	
	Throw (0 deg)	m	3.0	5.4	6.7	8.2	9.8	
250 x 250	Air Volume	l/s	98	159	221	282	344	
	Neck Velocity	m/s	1.8	2.9	4.0	5.1	6.3	
	Noise Level	NR	–	20	29	37	43	
	Pressure Loss	Pa	5	14	26	43	63	
	Throw (0 deg)	M	4.2	6.3	8.4	11.0	12.5	
300 x 300	Air Volume	l/s	141	230	318	407	495	
	Neck Velocity	m/s	1.7	2.8	3.9	5.0	6.1	
	Noise Level	NR	–	21	30	38	43	
	Pressure Loss	Pa	5	13	25	40	60	
	Throw (0 deg)	m	4.5	7.5	10.8	12.5	15.0	
350 x 350	Air Volume	l/s	192	313	433	554	674	
	Neck Velocity	m/s	1.7	2.8	3.8	4.9	6.0	
	Noise Level	NR	–	21	31	38	44	
	Pressure Loss	Pa	5	12	24	39	58	
	Throw (0 deg)	m	5.5	9.0	12.5	14.5	17.2	
400 x 400	Air Volume	l/s	251	408	566	723	880	
	Neck Velocity	m/s	1.7	2.7	3.8	4.8	5.9	
	Noise Level	NR	–	22	32	39	45	
	Pressure Loss	Pa	5	12	23	38	56	
	Throw (0 deg)	m	6.6	10.0	12.9	15.8	18.7	
450 x 450	Air Volume	l/s	318	517	716	915	1114	
	Neck Velocity	m/s	1.7	2.7	3.7	4.8	5.8	
	Noise Level	NR	–	23	33	40	46	
	Pressure Loss	Pa	4	12	23	37	55	
	Throw (0 deg)	m	7.8	11.0	14.5	16.2	20.5	

Performance Notes

Throw values are based on grilles or registers mounted in the sidewall not more than one metre below an unrestricted ceiling. For grilles located more than one metre below the ceiling, throw values should be reduced by approximately 25%.

Throw values are based on 10 °C cooling applications. For Isothermal throws multiply by 1.25.

Terminal Velocities are based on 0.25 m/s.

Each NR value represents the noise rating curve which will not be exceeded by the sound pressure in any of the octave bands, 125 Hz through to 4k Hz. Each NR value is based on a room absorption of 10 dB, re 10 watts. Each NR value is further based on register operating at a 0 degree deflection. Settings of 22.5 or 45 degree, increase the stated sound levels by 1 or 7 NR, respectively. A dash (-) in space indicates an NR value less than 10.

The NR level shown included for a grille with fully open obd fitted, a 2 dB reduction can be applied for grilles without an obd fitted. The effect of partly closing an obd for balancing purposes will significantly add to generated noise.

The pressure loss shown is for a grille with fully open obd fitted and the blades set for 0 degrees. For blades at 40 degrees a 50% addition should be applied. For grilles without an obd fitted a 10% reduction to the value shown can be applied.

For other performance or selection details please contact the sales office.

Model EC Egg Crate Grilles

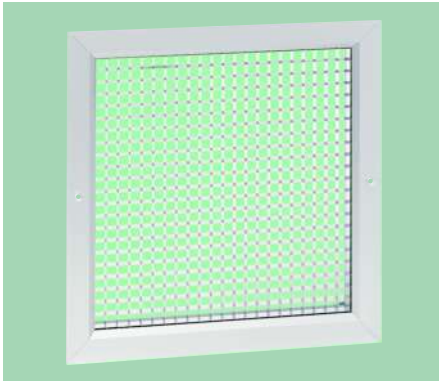

Model EC - No. 2 Finish

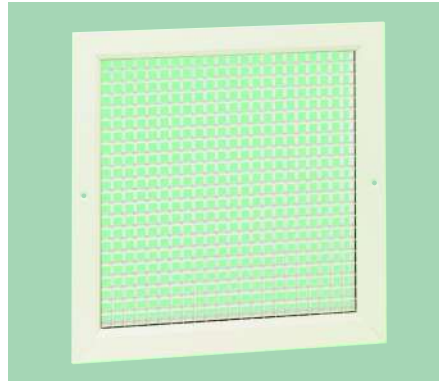

Model EC - No. 3 Finish

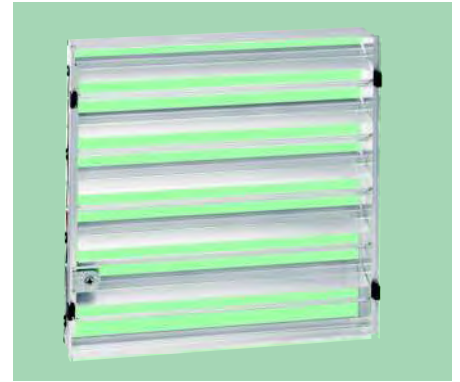

Model OBD

Description

Model EC egg crate grille incorporates a 12.5mm lattice style high free area core in either fixed or removable core versions. The grille is suitable for sidewall, soffit or ceiling mounting and is normally used for extract applications. Typical installations include offices, shops, hotels, restaurants, schools and most commercial or industrial buildings.

Available as standard in white polyester powder coat finish. Other polyester powder coat finishes are also available as an option.

Standard fixing is with No. 8 countersunk headed screws (BY OTHERS) using prepared countersunk screw holes in flange.

An optional opposed blade damper can be fitted to the rear of the grille and adjusted through the grille core.

Specification

Material

Extruded aluminium sections

Construction

25mm flange frame or 44mm wide flange with corners mitred and welded. (44mm wide flange only suitable for fixed core).

The fixed core is located within the outer frame extrusion and retained in situ by the flange frame.

The removable core is fitted into a "U" channel section and retained in the outer frame by securing screws (see drawing on page 17).

Installation Methods

F0 – No fixing (fixing BY OTHERS).

F1 – Countersunk Screw Holes in Flange (Standard).

F2 – Spring Clips (not recommended for ceiling or high sidewall installation).

F4 – Rear strap (concealed behind grille core) mating strap BY OTHERS.

F6 – Rear strap and Mating "U" bracket (requires hemmed duct BY OTHERS).

For Installation Guide see Page 37 / 38.

Accessories

Available fitted with opposed blade damper adjusted through the grille core.

Finish

0 – Mill extruded aluminium.

2 – Silver (RAL9006) polyester powder coat.

3 – White (RAL9010) 20% polyester powder coat (Standard).

4 – Black (RAL9005) polyester powder coat.

6 – Special polyester powder coat finish.

(Please state separately the RAL colour reference and finish type required).

Model Types

Model ECG – is supplied as a grille only with a fixed core.

Model ECG-RC – is supplied as a grille only with a removable core.

Model ECR – is supplied as a grille having fixed core and fitted with an OBD.

Model ECR-RC – is supplied as a grille having removable core and fitted with an OBD.

Dimensions

Minimum size is 100mm x 100mm up to a maximum single section of 1200mm x 1200mm. Special sizes also available.

Fixed Core (25mm Flange)

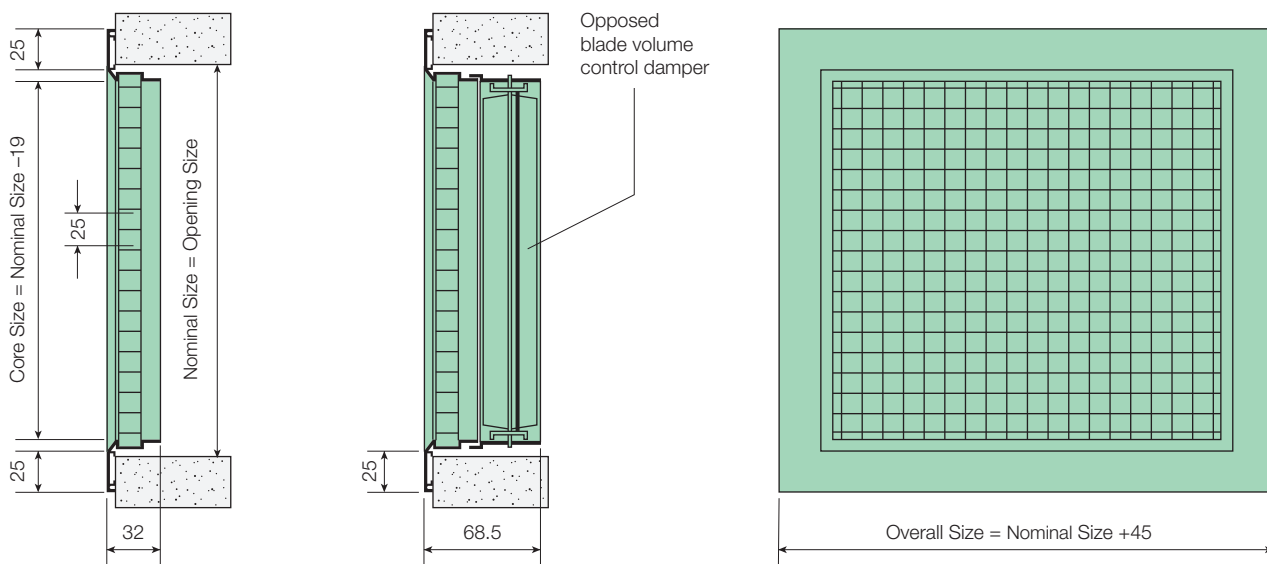

Wall and Ceiling Grilles

Removable Core

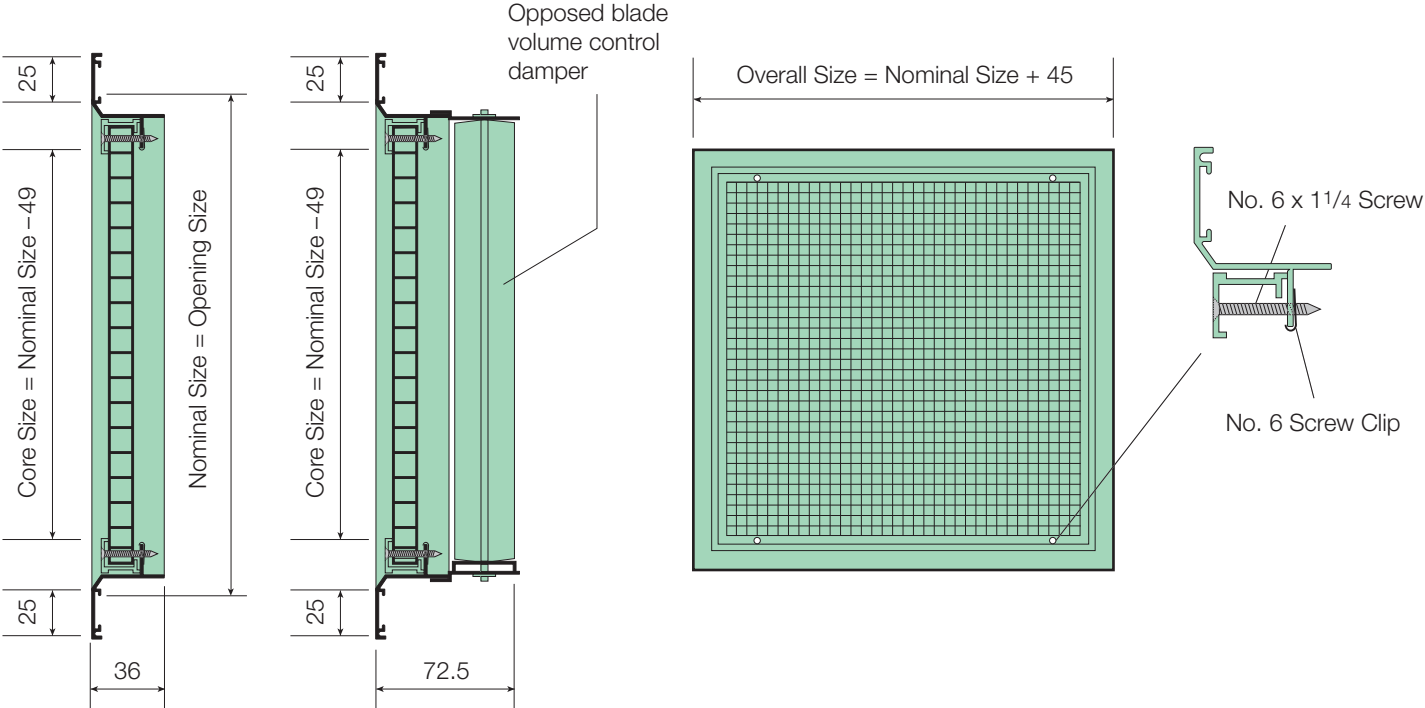

Wide Flange

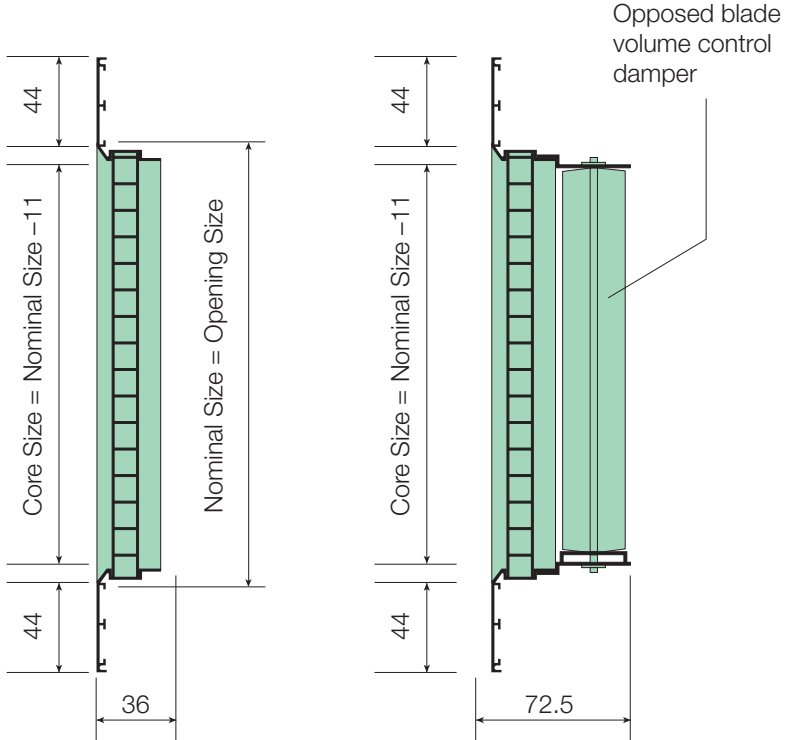
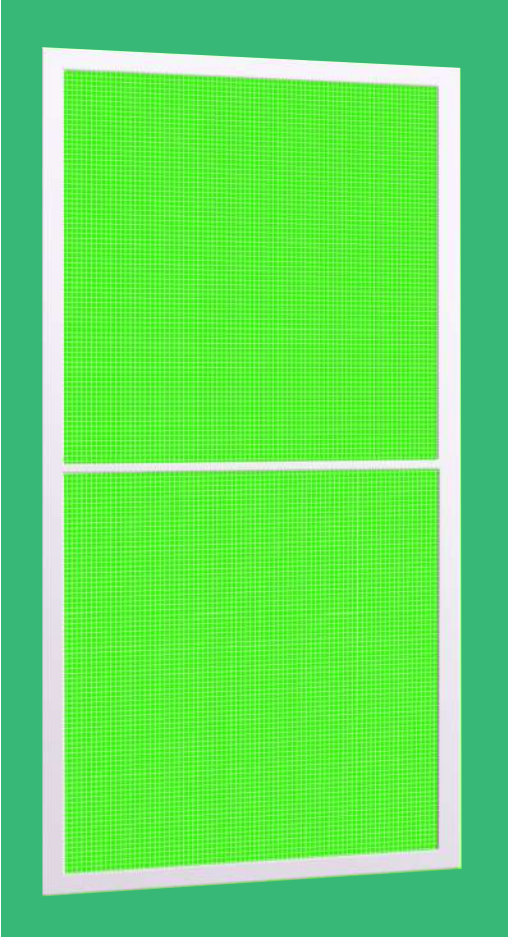

Model EC Egg Crate Grilles - Nomogram: Exhaust

Please refer to selection procedure for details.

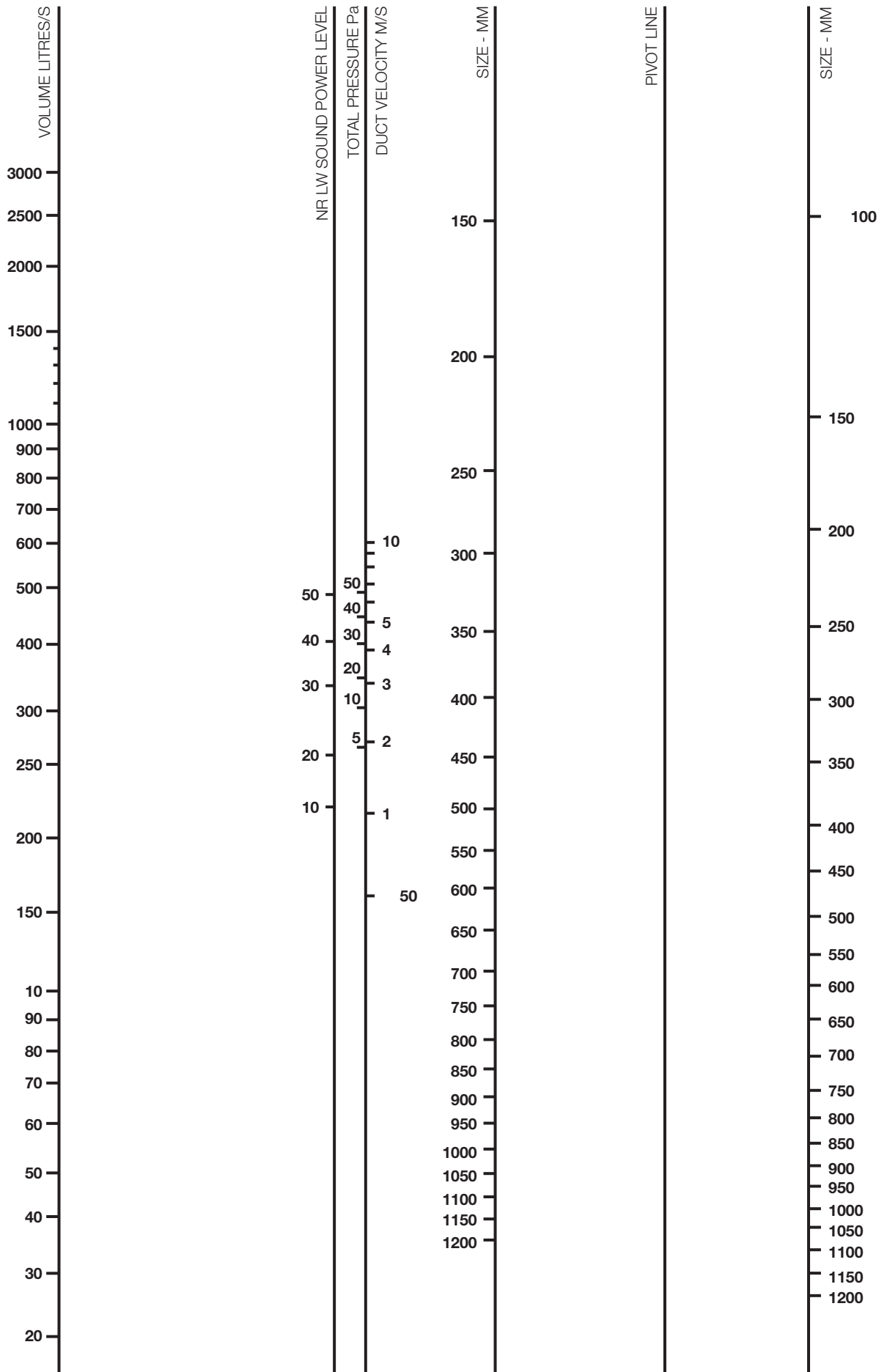

Quick Selection Performance Tables for Standard Sizes: Models ECG - ECR

Nominal Size w x h	Performance								
100 x 100	Air Volume	l/s	20	30	40	50	60	70	80
	Velocity	m/s	2.0	2.5	3.2	3.8	4.5	5.5	6.2
	Noise Level	NR	10	20	25	27	30	35	40
	Pressure Loss	Pa	5	10	20	25	32	35	48
150 x 150	Air Volume	l/s	40	50	60	70	80	90	100
	Velocity	m/s	1.5	1.75	2.3	2.75	3.0	3.5	3.9
	Noise Level	NR	–	12	18	21	24	28	30
	Pressure Loss	Pa	–	5	7	11	18	22	28
200 x 200	Air Volume	l/s	60	70	80	90	100	150	200
	Velocity	m/s	1.5	1.75	1.9	2.2	2.4	3.0	4.1
	Noise Level	NR	–	11	15	19	21	28	35
	Pressure Loss	Pa	–	–	5	6	8	19	29
250 x 250	Air Volume	l/s	70	80	90	100	150	200	250
	Velocity	m/s	1.0	1.2	1.5	1.75	2.2	2.8	3.8
	Noise Level	NR	–	–	10	12	21	27	33
	Pressure Loss	Pa	–	–	–	5	7	15	25
300 x 300	Air Volume	l/s	80	90	100	150	200	250	300
	Velocity	m/s	0.75	0.9	1.1	1.5	2.1	2.8	3.2
	Noise Level	NR	–	–	–	15	21	28	32
	Pressure Loss	Pa	–	–	–	–	7	13	21
350 x 350	Air Volume	l/s	90	100	150	200	250	300	400
	Velocity	m/s	0.75	0.8	1.1	1.5	2.1	2.5	3.2
	Noise Level	NR	–	–	–	15	21	27	32
	Pressure Loss	Pa	–	–	–	–	7	10	20
400 x 400	Air Volume	l/s	100	150	200	250	300	400	500
	Velocity	m/s	0.6	0.8	1.1	1.75	2.0	2.6	3.0
	Noise Level	NR	–	–	10	18	22	28	33
	Pressure Loss	Pa	–	–	–	–	6	10	20
450 x 450	Air Volume	l/s	150	200	250	300	400	500	600
	Velocity	m/s	0.7	0.9	1.2	1.6	2.1	2.75	2.9
	Noise Level	NR	–	–	13	19	25	28	33
	Pressure Loss	Pa	–	–	–	–	6	10	18
500 x 500	Air Volume	l/s	200	250	300	400	500	600	700
	Velocity	m/s	0.75	0.9	1.2	1.8	2.2	2.5	2.8
	Noise Level	NR	–	–	14	21	25	28	32
	Pressure Loss	Pa	–	–	–	–	6	10	15
550 x 550	Air Volume	l/s	250	300	400	500	600	700	800
595 x 595	Velocity	m/s	0.75	1.0	1.5	1.8	2.2	2.5	2.8
Overall	Noise Level	NR	–	11	18	23	26	28	33
	Pressure Loss	Pa	–	–	–	–	7	9	15

Performance Notes

The tables are based on the grille being used for extract purposes.

The total pressure losses given are for the grille fitted with a fully open damper. For grilles without dampers a 10% reduction may be applied.

The noise rating levels include for a grille fitted with a fully open damper. For grilles without dampers a 2 dB reduction may be applied. The effect of part closing a damper will significantly add to the noise rating levels. A dash (–) in space indicates a noise ratings level lower than 10 NR.

Where a dash (–) in space is shown this indicates a Pressure Loss less than 5 Pa.

For other performance or selection details please contact the sales office.

Model PG Perforated Grille



Model PG- No. 3 Finish

Description

Model PG perforated core grille incorporates a 32% free area steel mesh core in an aluminium flange frame. The grille is suitable for sidewall, soffit or ceiling mounting and is normally used for extract applications. Typical installations include offices, shops, hotels, restaurants, schools and most commercial or industrial buildings.

Available as standard in white polyester powder coat finish. Other polyester powder coat finishes are also available as an option.

Standard fixing is with No.8 countersunk headed screws (BY OTHERS) using prepared countersunk screw holes in flange.

An optional opposed blade damper can be fitted to the rear of the grille and adjusted through a prepared hole in the grille core.

Specification

Material

Extruded aluminium sections with a steel core.

Construction

25mm wide flange frame with corners mitred and welded. The fixed perforated steel core is located within the outer frame extrusion and retained in situ by the flange frame.

Installation Methods

F0 – No fixing (fixing BY OTHERS).

F1 – Countersunk Screw Holes in Flange (**Standard**).

F2 – Spring Clips (not recommended for ceiling or high sidewall installation).

For Installation Guide see Page 26.

Accessories

Available fitted with opposed blade damper adjusted through a prepared hole in the grille core.

Finish

2 – Silver (RAL9006) polyester powder coat

3 – White (RAL9010) 20% polyester powder coat (**Standard**).

4 – Black (RAL9005) polyester powder coat.

6 – Special polyester powder coat. (Please state separately the RAL colour reference and finish type).

Model Types

Model PG – is supplied as a grille only with a fixed core.

Model PGR – is supplied as a grille having fixed core and fitted with an OBD.

Dimensions

Minimum size is 100mm x 100mm up to a maximum single section of 1000mm x 1000mm. Special sizes also available.

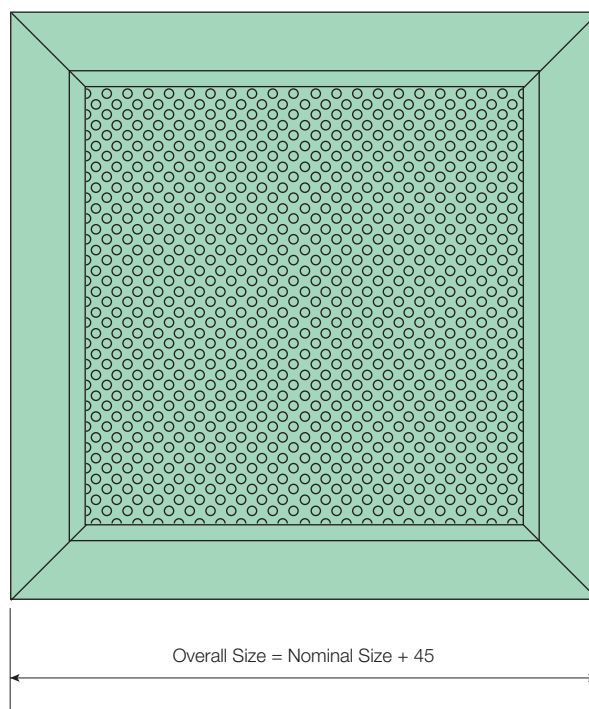
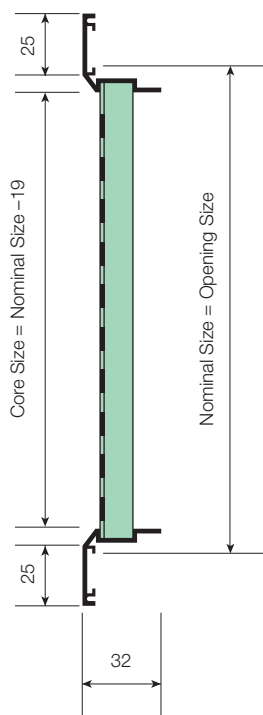

Model G45 Fixed Blade Grille



Model G45 - No. 2 Finish

Description

Model G45 fixed blade grille incorporates a set of 45° aluminium blades, which can be provided in either a one way or two way format. The grille is suitable for sidewall, soffit or ceiling mounting and is normally used for extract applications. By installing above or below eye level the grille is sight-proof, these grilles can also be provided as a continuous assembly. Typical installations include offices, shops, hotels, restaurants, schools and most commercial or industrial buildings.

Available as standard in white polyester powder coat finish. Other polyester powder coat finishes are also available as an option.

Standard fixing is with No.8 countersunk headed screws (BY OTHERS) using prepared countersunk screw holes in flange.

An optional opposed blade damper can be fitted to the rear of the grille and adjusted through a prepared hole in the grille core.

Specification

Material

Extruded aluminium sections

Construction

25mm wide flange frame with corners mitred and welded. The core uses a tube and spacer alignment at a maximum of 350mm centres and is secured into the frame with the tube passing through each blade.

Installation Methods

F0 – No fixing (fixing BY OTHERS).

F1 – Countersunk Screw Holes in Flange (**Standard**).

F2 – Spring Clips (not recommended for ceiling or high sidewall installation).

F4 – Rear strap (concealed behind grille core) mating strap BY OTHERS.

F6 – Rear strap and Mating “U” bracket (requires hemmed duct BY OTHERS).

For Installation Guide see Page 37.

Accessories

Available fitted with opposed blade damper adjusted through a prepared hole in the grille core.

Finish

0 – Mill extruded aluminium.

2 – Silver (RAL9006) polyester powder coat.

3 – White (RAL9010) 20% polyester powder coat (**Standard**).

4 – Black (RAL9005) polyester powder coat.

6 – Special polyester powder coat (Please state separately the RAL colour reference and finish type required).

Model Types

Model G45G – is supplied as a grille only with a 1 way fixed core.

Model G45R – is supplied as a grille having 1 way fixed core and fitted with an OBD.

Please state separately if a 2 way core is required.

Dimensions

Minimum size is 100mm x 100mm up to a maximum single section of 1000mm x 1000mm. Special sizes also available.

Type G45G

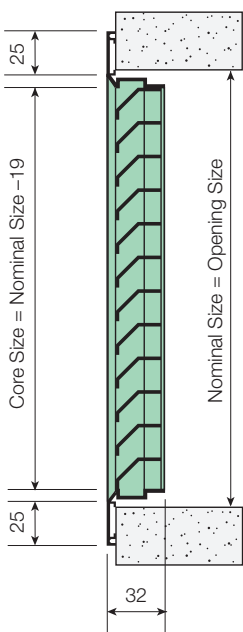

Type G45R

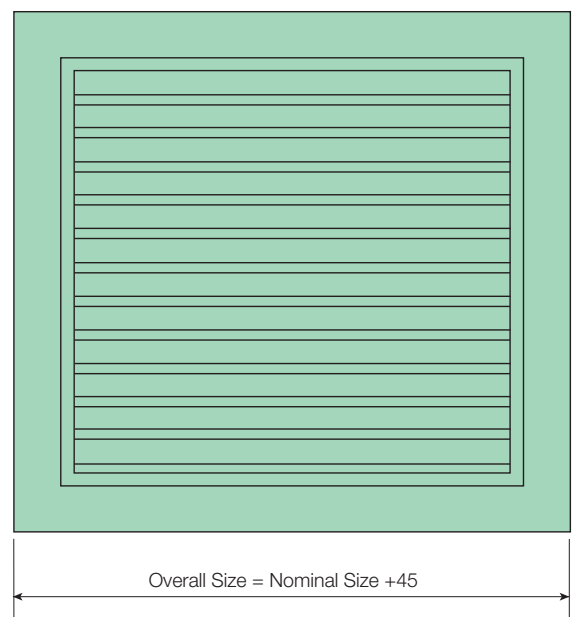
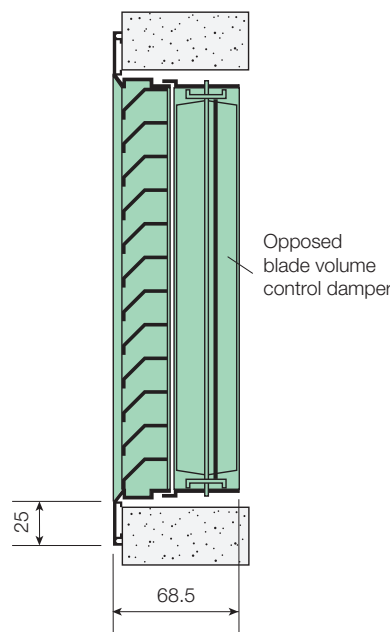

Model G45 Fixed Blade Grille - Performance Guide

Selection Guide

1. Determine air volume flow rate per outlet.
2. Establish required maximum noise and pressure values – refer to the appropriate nomogram.
3. With a straight edge line across from the litres per second value through values within the maximum parameters established to the pivot line.
4. Retaining the position of intersection at the pivot line, pivot the straight edge until it meets acceptable values of size to its left and right.

Note:

The pivot line represents an area and by maintaining position on this line widths and heights can be selected of equal area. See note regarding effect of aspect ratio on throw for supply applications.

Please refer to additional note in SD/DD section with regard to air jet characteristics under various conditions.

Pressure Loss

The total pressure losses given are for grilles and dampers fitted with the damper fully open. A 10% reduction of the value can be taken for grilles without dampers.

Sound Levels

Wherever possible we give NR power levels generated by the product. This enables the allowances for room characteristics, surface mounting and multiple outlets from the sound advice leaflet to be taken into account and more accurately predict the sound pressure measured in the occupied space.

The NR power level given for EC series grilles includes for a fully open damper, for grilles without dampers 2dB can be subtracted, however, the effect of partly closing the damper for balancing purposes can add significantly to generated noise.

Core area (m²) – Preferred size

Nom. Ht mm	Nominal Width – mm													
	150	200	250	300	350	400	500	600	700	800	900	1000	1100	1200
100	.0077	.0110	.0143	.0176	.0209	.0242	.0308	.0374	.0440	.0506	.0572	.0638	.0704	.0770
150	.0136	.0193	.0251	.0309	.0637	.0425	.0541	.0657	.0773	.0889	.1005	.1121	.1237	.1353
200		.0276	.0359	.0442	.0525	.0608	.0774	.0940	.1106	.1272	.1438	.1604	.1770	.1936
250			.0467	.0574	.0683	.0791	.1007	.1223	.1439	.1655	.1871	.2087	.2303	.2519
300				.0708	.0841	.0974	.1240	.1506	.1772	.2038	.2304	.2570	.2836	.3102
400						.1340	.1706	.2072	.2438	.2804	.3170	.3536	.3902	.4268
500							.2172	.2638	.3104	.3570	.4036	.4502	.4968	.5434
600								.3204	.3770	.4336	.4902	.5468	.6034	.6600

Free area factors:

G45 = 0.45

Based on 300 x 300 nominal size the figures above may vary by 5% dependent on grille size.

Model G45 Fixed Blade Grille - Nomogram: Exhaust

Please refer to selection procedure for details.

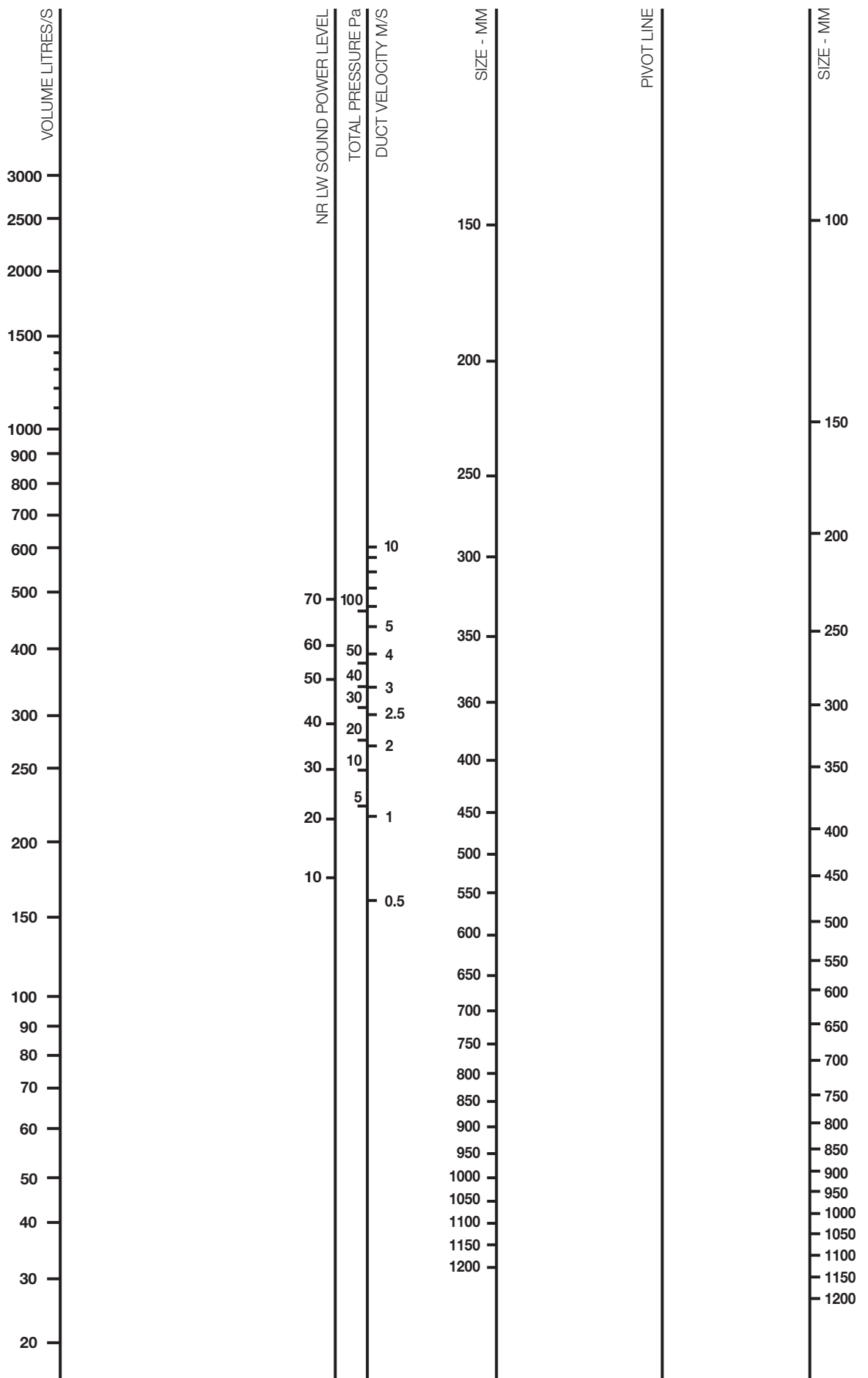

Model NVG Non Vision Air Transfer Grille



Model NVG - No. 3 Finish

Model NVG-MF - No. 2 Finish

Description

Model NVG non vision air transfer grille incorporates a set of inverted vee section vanes to ensure a vision proof assembly. A matching flange is available for either standard or extra wide doors or partition. The grille is suitable for sidewall, door or partition mounting and is normally used for extract or air transfer applications. Typical installations include offices, shops, hotels, restaurants, schools and most commercial or industrial buildings.

Available as standard in white polyester powder coat finish. Other polyester powder coat finishes are also available as an option.

Standard fixing is with No.8 countersunk headed screws (BY OTHERS) using prepared countersunk screw holes in flange.

Specification

Material

Extruded aluminium sections

Construction

25mm wide flange frame with corners mitred and welded. Overlapping inverted "v" aluminium sections are used for the vision proof core.

Installation Methods

F0 – No fixing (fixing BY OTHERS).

F1 – Countersunk Screw Holes in Flange **(Standard)**.

For Installation Guide see Page 37.

Accessories

Standard matching flange for 27mm to 54mm door/partition.

Deep matching flange for 56mm to 80mm door/partition.

Double core for light-proof applications.

Finish

0 – Mill extruded aluminium.

2 – Silver (RAL9006) polyester powder coat.

3 – White (RAL9010) 20% polyester powder coat **(Standard)**.

4 – Black (RAL9005) polyester powder coat.

6 – Special polyester powder coat ((Please state separately the RAL colour reference and finish type required).

Model Types

Model NVG – is supplied as a grille only.

Model NVG-MF – is supplied as a grille with a standard matching flange.

Model NVG-DF – is supplied as a grille with a deep matching flange.

Dimensions

Minimum size is 100mm x 100mm up to a maximum single section of 1200mm x 1200mm. Special sizes also available.

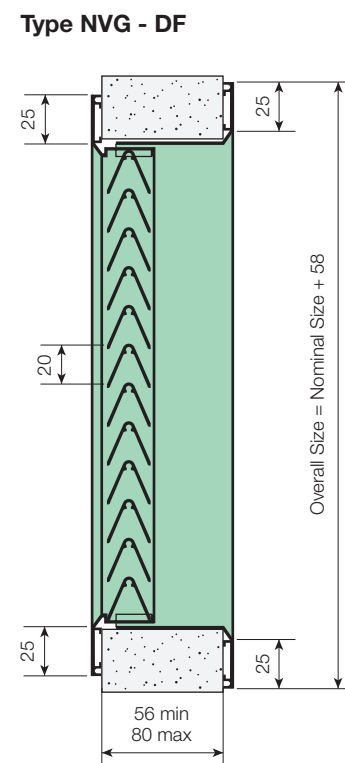
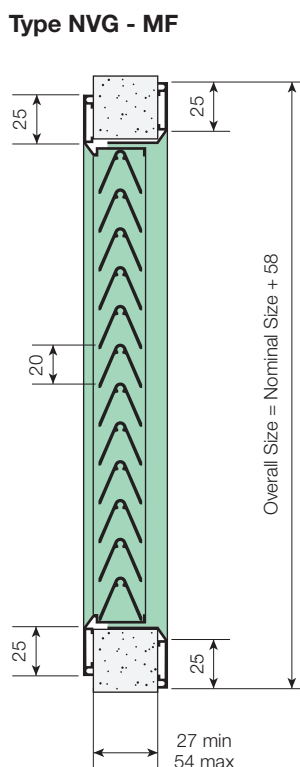
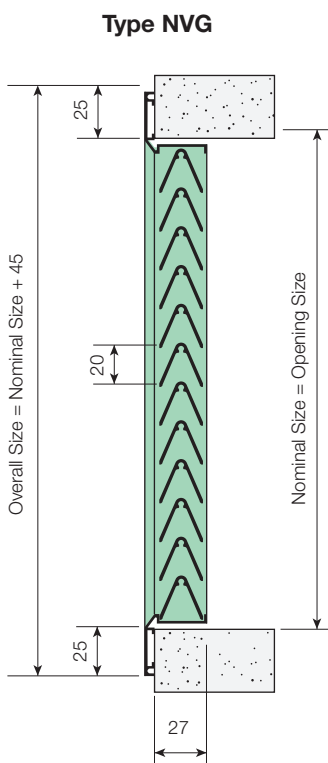

Model NVG Non Vision Air Transfer Grille

Selection Procedure

Typical selection of the most common sizes are given in the table opposite although a full range of sizes is available. When transferring air into critical spaces such as office it is good practice to limit face velocities to about 1.0m/s. When transferring into non critical spaces such as corridors, velocities can be increased up to the maximum sound or pressure limits.

Nominal Size mm	Volume Litres/sec	Face Velocity m/s	Total Pressure Pa	Sound Power Level
200 x 200	20	0.5	4	10
	30	0.75	7	14
	40	1.00	10	17
	50	1.25	14	22
	60	1.5	20	26
	70	1.75	26	31
300 x 300	45	0.5	4	10
	68	1.75	7	18
	90	1.00	10	23
	113	1.25	14	27
	135	1.5	19	30
	158	1.75	25	34
450 x 300	68	0.5	4	13
	100	0.75	7	18
	135	1.00	10	24
	170	1.25	14	30
	200	1.5	19	33
	236	1.75	25	37
450 x 450	100	0.5	4	14
	150	0.75	7	21
	200	1.00	10	26
	250	1.25	14	32
	300	1.5	19	36
	350	1.75	25	40

Model NB Narrow Blade Bar Grille

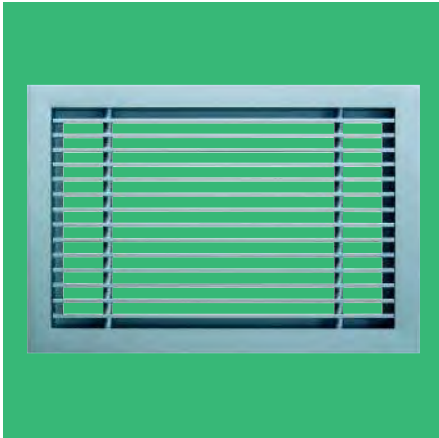

Model 20W NB0 - 0° Deflection No. 2 finish

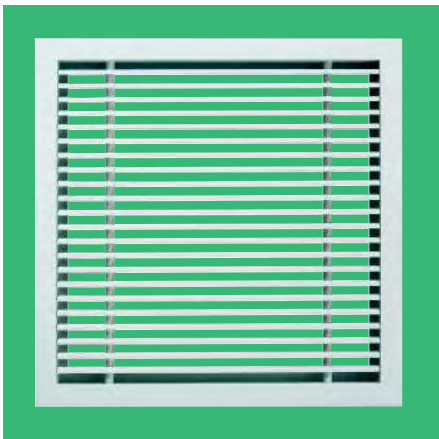

Model 20W NB15 - 15° Deflection No. 3 finish

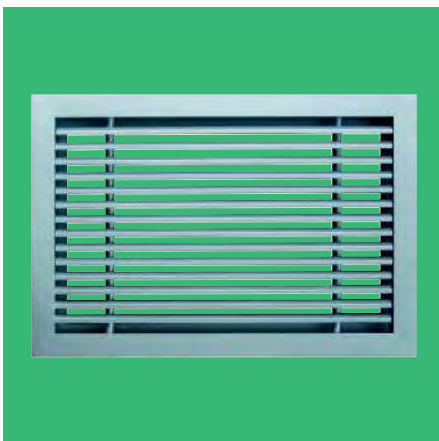

Model 20W NB30 - 30° Deflection No. 2 finish

Description

Model NB narrow blade bar type grille incorporates a 3.5mm wide blade on a 12.5mm pitch. The blades are offered in 3 separate deflection angles, 0°, 15° or 30° and may be either horizontal or vertical. The core assembly can be supplied either fixed or removable. Four frame sizes are available, 20mm, 25mm, 32mm and 44mm. The grille is suitable for sidewall, soffit or cill mounting and may be used for supply or extract applications. Typical installations include offices, shops, hotels, sports halls and most commercial or industrial buildings.

Available as standard in white polyester powder coat finish. Other polyester powder coat finishes are also available as an option.

Standard fixing for flange sizes 25mm, 32mm and 44mm is with No. 6 countersunk headed screws (BY OTHERS) using prepared countersunk screw holes in the flange. For flange size 20mm either secret fixing (F6) or spring clip fixing (F2) is used. A total of 8 alternative installation methods are available, although spring clip fixing (F2) is not recommended for high sidewall or ceiling installation.

An optional opposed blade damper can be fitted to the rear of the grille, which is adjusted through the grille core.

Specification

Material

Extruded aluminium sections.

Construction

20mm, 25mm, 32mm or 44mm wide flange frame with corners mitred and welded. Fixed blades are 3.5mm wide on a 12.5mm pitch and secured into the frame by 8mm tubular mullions on a maximum of 350mm centres.

Installation Methods

- F0** – No fixing (fixing BY OTHERS).
- F1** – Countersunk Screw Holes in Flange, Standard (25mm, 32mm & 44mm flange).
- F2** – Spring Clips, (not recommended for ceiling or high sidewall installation).
- F4** – Rear strap (concealed behind grille core) mating strap BY OTHERS.
- F6** – Rear strap and Mating “U” bracket (requires hemmed duct BY OTHERS).
- F8** – Ceiling Alignment Clip, details of ceiling type and clip to be provided.

For Installation Guide see Pages 37/38.

Accessories

Available fitted with opposed blade damper adjusted through the grille core.

Removable core, spring terry clip.

Finish

- 0** – Mill extruded aluminium.
- 2** – Silver (RAL9006) polyester powder coat.
- 3** – White (RAL9010) 20% polyester powder coat (**Standard**).
- 4** – Black (RAL9005) polyester powder coat.
- 5** – Brushed (Linished) natural aluminium face surfaces, 20mm and 32mm frame only.
- 6** – Special polyester powder coat (Please state separately the RAL colour reference and finish type required).

Model Types

Model NB0-G is supplied as a grille only with 0° deflection, 3.5mm blades on 12.5mm pitch.

Model NB15-G is supplied as a grille only with 15° deflection, 3.5mm blades on 12.5mm pitch.

Model NB30-G is supplied as a grille only with 30° deflection, 3.5mm blades on 12.5mm pitch.

A prefix of 20W, 25W, 32W or 44W determines the flange width (ie. Model type 25W-NB15-G is a grille only with 25mm wide flange and 15 degree deflection blades).

For an opposed blade damper replace the letter ‘G’ with the letter ‘R’ (ie. Model type 25W-NB15-R is a grille having a 25mm wide flange, 15 degree deflection blades and fitted with an opposed blade damper).

Dimensions

Minimum size is 100mm x 100mm up to a maximum single section of 1800mm x 1200mm. Special sizes also available.

Model GN Narrow Blade Bar Grille

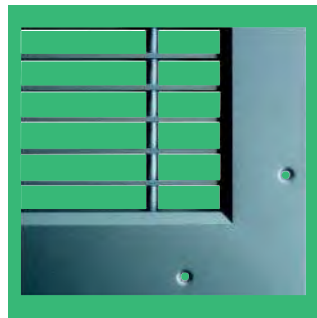

Model 44W GN0 - 0° Deflection – No. 2 finish, with corner detail.

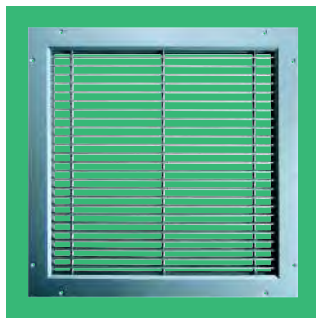

Model 44W GN15 - 15° Deflection – No. 2 finish, with corner detail.

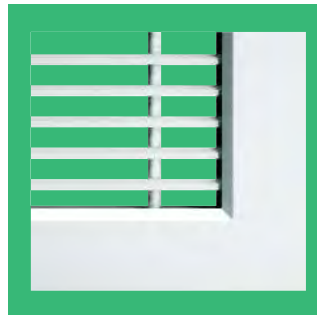

Model 44W GN30 - 30° Deflection – No. 3 finish, with corner detail.

Description

Model GN narrow blade bar type grille incorporates a 3.5mm wide blade on a 19mm pitch. The blades are offered in 3 separate deflection angles, 0°, 15° or 30° and may be either horizontal or vertical. The core assembly can be supplied either fixed or removable. Four frame sizes are available, 20mm, 25mm, 32mm and 44mm. The grille is suitable for sidewall, soffit or cill mounting and may be used for supply or extract applications. Typical installations include offices, shops, hotels, sports halls and most commercial or industrial buildings. Available as standard in white

polyester powder coat finish. Other polyester powder coat finishes are also available as an option.

Standard fixing for flange sizes 25mm, 32mm and 44mm is with No. 8 countersunk headed screws (BY OTHERS) using prepared countersunk screw holes in the flange. For flange size 20mm either secret fixing (F6) or spring clip fixing (F2) is used. A total of 6 alternative installation methods are available, although spring clip fixing (F2) is not recommended for high sidewall or ceiling installation.

An optional opposed blade damper can be fitted to the rear of the grille, which is adjusted through the grille core.

Specification

Material

Extruded aluminium sections.

Construction

20mm, 25mm, 32mm or 44mm wide flange frame with corners mitred and welded. Fixed blades are 3.5mm wide on a 19mm pitch and secured into the frame by 8mm tubular mullions on a maximum of 350mm centres.

Installation Methods

F0 – No fixing (fixing BY OTHERS).

F1 - Countersunk Screw Holes in Flange, Standard (25mm, 32mm and 44mm flange).

F2 – Spring Clips, Standard (20mm flange) (not recommended for ceiling or high sidewall installation).

F4 – Rear strap (concealed behind grille core) mating strap BY OTHERS.

F6 – Rear strap and Mating “U” bracket (requires hemmed duct BY OTHERS).

F8 – Ceiling Alignment Clip, details of ceiling type and clip to be provided.

For Installation Guide see Pages 37/38.

Accessories

Available fitted with opposed blade damper adjusted through the grille core.

Removable core, spring terry clip.

Finish

0 – Mill extruded aluminium.

2 – Silver (RAL9006) polyester powder coat.

3 – White (RAL9010) 20% polyester powder coat **(Standard)**.

4 – Black (RAL9005) polyester powder coat.

5 – Brushed (Linished) natural aluminium face surfaces, 20mm and 32mm frame only.

6 – Special polyester powder coat finish (Please state separately the RAL colour reference and finish type required).

Model Types

Model GN0-G is supplied as a grille only with 0° deflection, 3.5mm blades on 19mm pitch.

Model GN15-G is supplied as a grille only with 15° deflection, 3.5mm blades on 19mm pitch.

Model GN30-G is supplied as a grille only with 30° deflection, 3.5mm blades on 19mm pitch.

A prefix of 20W, 25W, 32W or 44W determines the flange width (i.e. Model type 25W-GN15-G is a grille only with 25mm wide flange and 15 degree deflection blades).

For an opposed blade damper replace the letter ‘G’ with the letter ‘R’ (ie. Model type 25W-GN15-R is a grille having a 25mm wide flange, 15 degree deflection blades and fitted with an opposed blade damper).

Dimensions

Minimum size is 100mm x 100mm up to a maximum single section of 1800mm x 1200mm. Special sizes also available.

Dimensions see drawings on pages 30 and 31.

Model WB Wide Blade Bar Grille

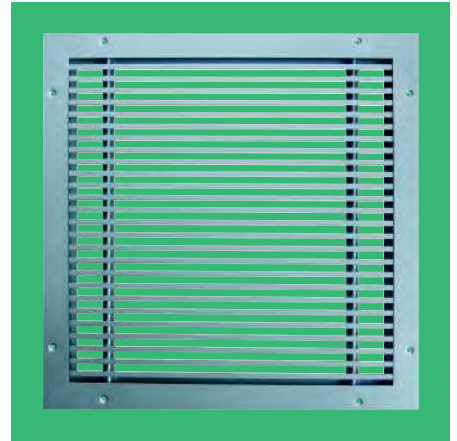

Model 25W WB0 - 0° Deflection
No. 3 finish.

Description

Model WB wide blade bar type grille incorporates a 6.5mm wide blade on a 14mm pitch. The blades are offered in 2 separate deflection angles, 0° or 15° and may be either horizontal or vertical. The core assembly can be supplied either fixed or removable. Four frame sizes are available, 20mm, 25mm, 32mm and 44mm. The grille is suitable for sidewall, soffit or cill mounting and may be used for supply or extract applications. Typical installations include offices, shops, hotels, sports halls and most commercial or industrial buildings.

Available as standard in white polyester powder coat finish Other polyester powder coat finishes are also available as an option.

Standard fixing for flange sizes 25mm, 32mm and 44mm is with No. 8 countersunk headed screws (BY OTHERS) using prepared countersunk screw holes in the flange. For flange size 20mm either secret fixing (F6) or spring clip fixing (F2) is used. A total of 8 alternative installation methods are available, although spring clip fixing (F2) is not recommended for high sidewall or ceiling installation.

An optional opposed blade damper can be fitted to the rear of the grille, which is adjusted through the grille core.

Specification

Material

Extruded aluminium sections

Construction

20mm, 25mm, 32mm or 44mm wide flange frame with corners mitred and welded. Fixed blades are 6.5mm wide on a 14mm pitch and secured into the frame by 8mm tubular mullions on a maximum

Model 25W WB15 - 15° Deflection
No. 3 finish.

of 350mm centres.

Installation Methods

F0 – No fixing (fixing BY OTHERS).

F1 – Countersunk Screw Holes in Flange, Standard (25mm, 32mm and 44mm flange).

F2 – Spring Clips, Standard (20mm flange) (not recommended for ceiling or high sidewall installation)

F4 – Rear strap (concealed behind grille core) mating strap BY OTHERS.

F6 – Rear strap and Mating “U” bracket requires hemmed duct BY OTHERS).

F8 – Ceiling Alignment Clip, details of ceiling type and clip to be provided.

F10 – Removable core, spring terry clip. For Installation Guide see Pages 37/38.

Accessories

Available fitted with opposed blade damper adjusted through the grille core. Removable Core, spring terry clip.

Finish

0 – Mill extruded aluminium.

2 – Silver (RAL9006) polyester powder coat.

3 – White (RAL9010) 20% gloss polyester powder coat. (Standard)

4 – Black (RAL9005) polyester powder coat.

5 – Brushed (Linished) natural aluminium face surfaces, 20mm and 32mm frame only.

6 – Special polyester powder coat finish (Please state separately the RAL colour reference and finish type required).

Model 32W WB0 - 0° Deflection
No. 2 finish.

Model Types

Model WB0-G is supplied as a grille only with 0° deflection, 6.5mm blades on 14mm pitch.

Model WB15-G is supplied as a grille only with 15° deflection, 6.5mm blades on 14mm pitch.

A prefix of 20W, 25W, 32W or 44W determines the flange width (ie. Model type 25W-WB15-G is a grille only with 25mm wide flange and 15 degree deflection blades).

For an opposed blade damper replace the letter ‘G’ with the letter ‘R’ (ie. Model type 25W-WB15-R is a grille having a 25mm wide flange, 15 degree deflection blades and fitted with an opposed blade damper).

Dimensions

Minimum size is 100mm x 100mm up to a maximum single section of 1800mm x 1200mm. Special sizes also available.

See drawings on pages 30 and 31.

Model GW Wide Blade Grille

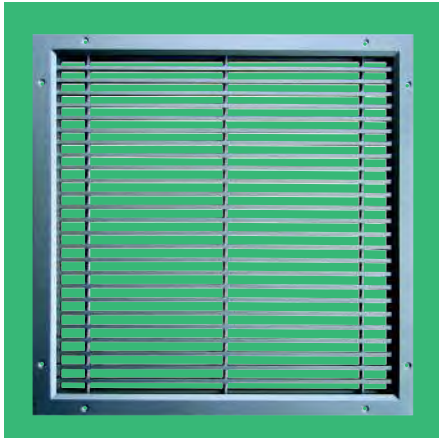

Model 25W GW0 - 0° Deflection
No. 2 finish.

Description

Model GW wide blade bar type grille incorporates a 6.5mm wide blade on a 19mm pitch. The blades are offered in 2 separate deflection angles, 0° or 15° and may be either horizontal or vertical. The core assembly can be supplied either fixed or removable. Four frame sizes are available, 20mm, 25mm, 32mm and 44mm. The grille is suitable for sidewall, soffit or cill mounting and may be used for supply or extract applications. Typical installations include offices, shops, hotels, sports halls and most commercial or industrial buildings.

Available as standard in white polyester powder coat finish. Other polyester powder coat finishes are also available as an option.

Standard fixing for flange sizes 25mm, 32mm and 44mm is with No. 8 countersunk headed screws (BY OTHERS) using prepared countersunk screw holes in the flange. For flange size 20mm either secret fixing (F6) or spring clip fixing (F2) is used. A total of 8 alternative installation methods are available, although spring clip fixing (F2) is not recommended for high sidewall or ceiling installation.

An optional opposed blade damper can be fitted to the rear of the grille, which is adjusted through the grille core.

Specification

Material

Extruded aluminium sections.

Construction

20mm, 25mm, 32mm or 44mm wide flange frame with corners mitred and welded. Fixed blades are 6.5mm wide on a 19mm pitch and secured into the frame by 8mm tubular mullions on a maximum of 350mm centres.



Model 44W GW15 - 15° Deflection
No. 3 finish.

Installation Methods

F0 – No fixing (fixing BY OTHERS).

F1 – Countersunk Screw Holes in Flange, Standard (25mm, 32mm & 44mm flange).

F2 – Spring Clips, Standard (20mm flange) (not recommended for ceiling or high sidewall installation).

F4 – Rear strap (concealed behind grille core) mating strap BY OTHERS.

F6 – Rear strap and Mating “U” bracket (requires hemmed duct BY OTHERS).

F8 – Ceiling Alignment Clip, details of ceiling type and clip to be provided.

F10 – Removable core, spring terry clip.

For Installation Guide see Pages 37/38.

Accessories

Available fitted with opposed blade damper adjusted through the grille core.

Removable Core.

Finish

0 – Mill extruded aluminium.

2 – Silver (RAL9006) polyester powder coat.

3 – White (RAL9010) 20% gloss polyester powder coat (Standard).

4 – Black (RAL9005) polyester powder coat.

5 – Brushed (Linished) natural aluminium face surfaces. 32mm frame only.

6 – Special polyester powder coat finish. (Please state separately the RAL colour reference and finish type required).

Model Types

Model GW0-G is supplied as a grille only with 0° deflection, 6.5mm blades on 19mm pitch.

Model GW15-G is supplied as a grille only with 15° deflection, 6.5mm blades on 19mm pitch.

A prefix of 20W, 25W, 32W or 44W determines the flange width (ie. Model type 25W-GW15-G is a grille only with 25mm wide flange and 15 degree deflection blades).

For an opposed blade damper replace the letter ‘G’ with the letter ‘R’ (ie. Model type 25W-GW15-R is a grille having a 25mm wide flange, 15 degree deflection blades and fitted with an opposed blade damper).

Dimensions

Minimum size is 100mm x 100mm up to a maximum single section of 1800mm x 1200mm. Special sizes also available.

Dimensions

20mm Border Not available with Flange Fixing Holes

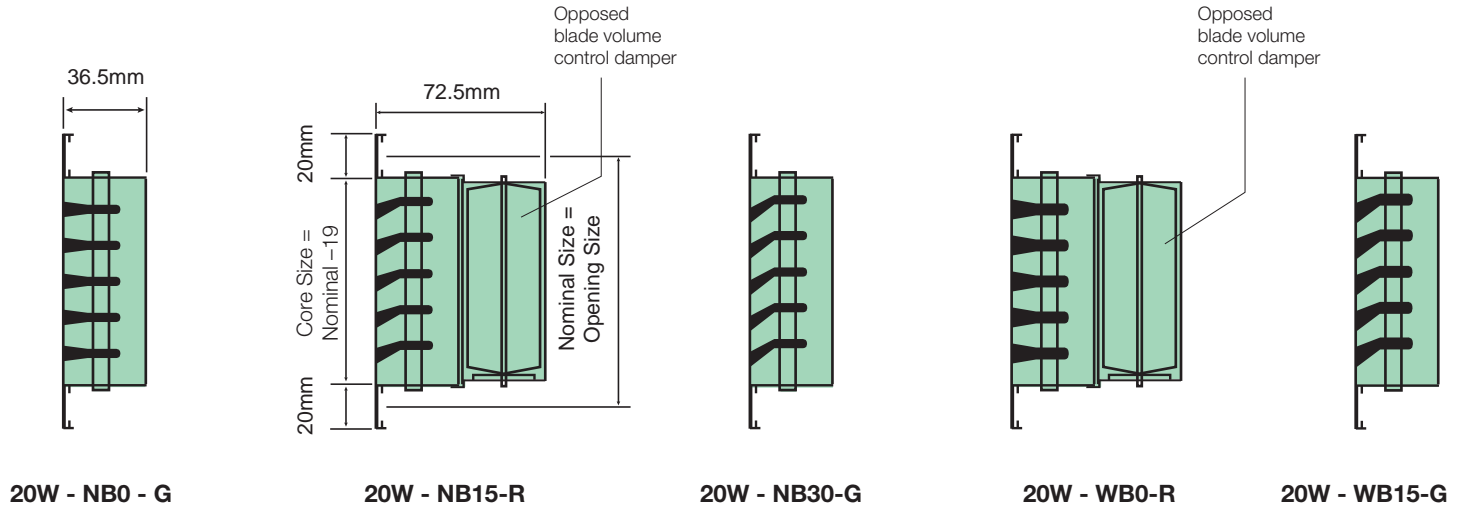

25mm Border

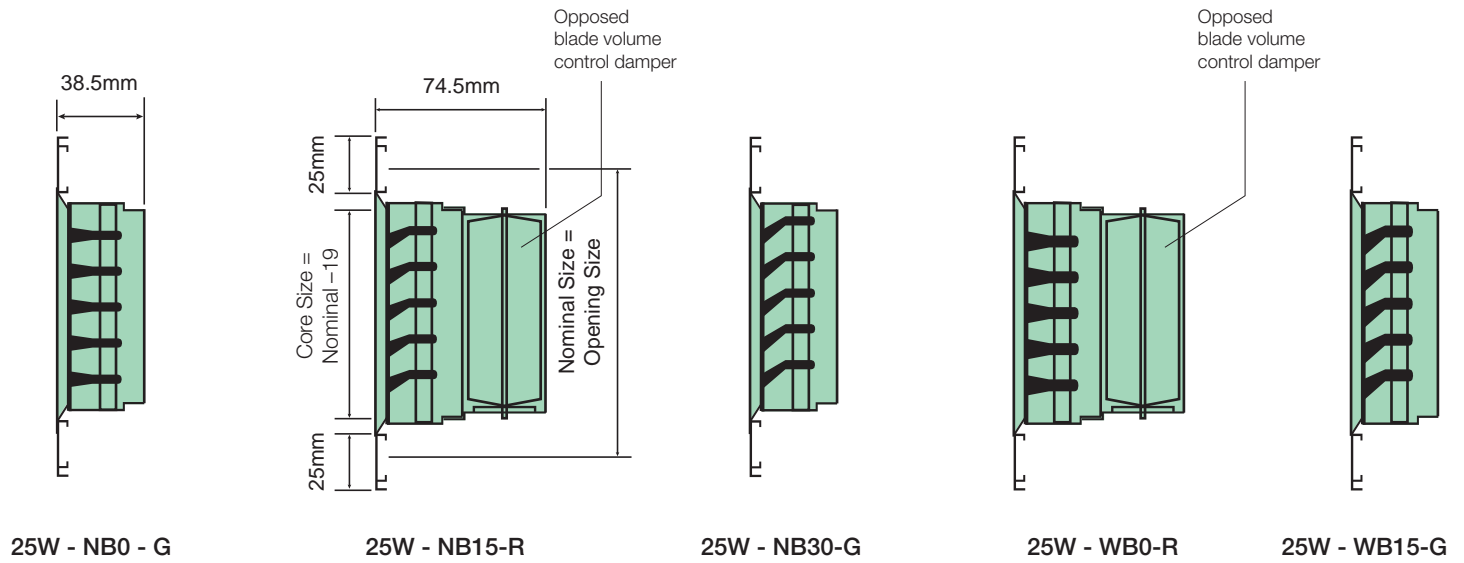

Dimensions

32mm Border

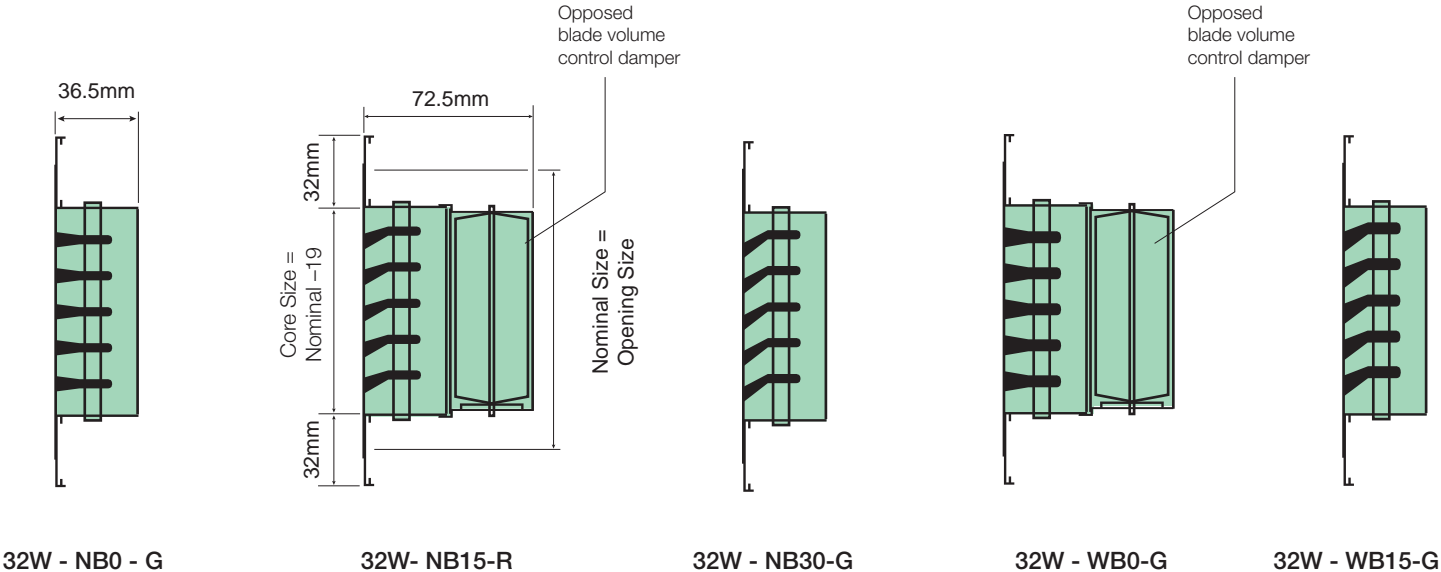

25mm Border Model GN

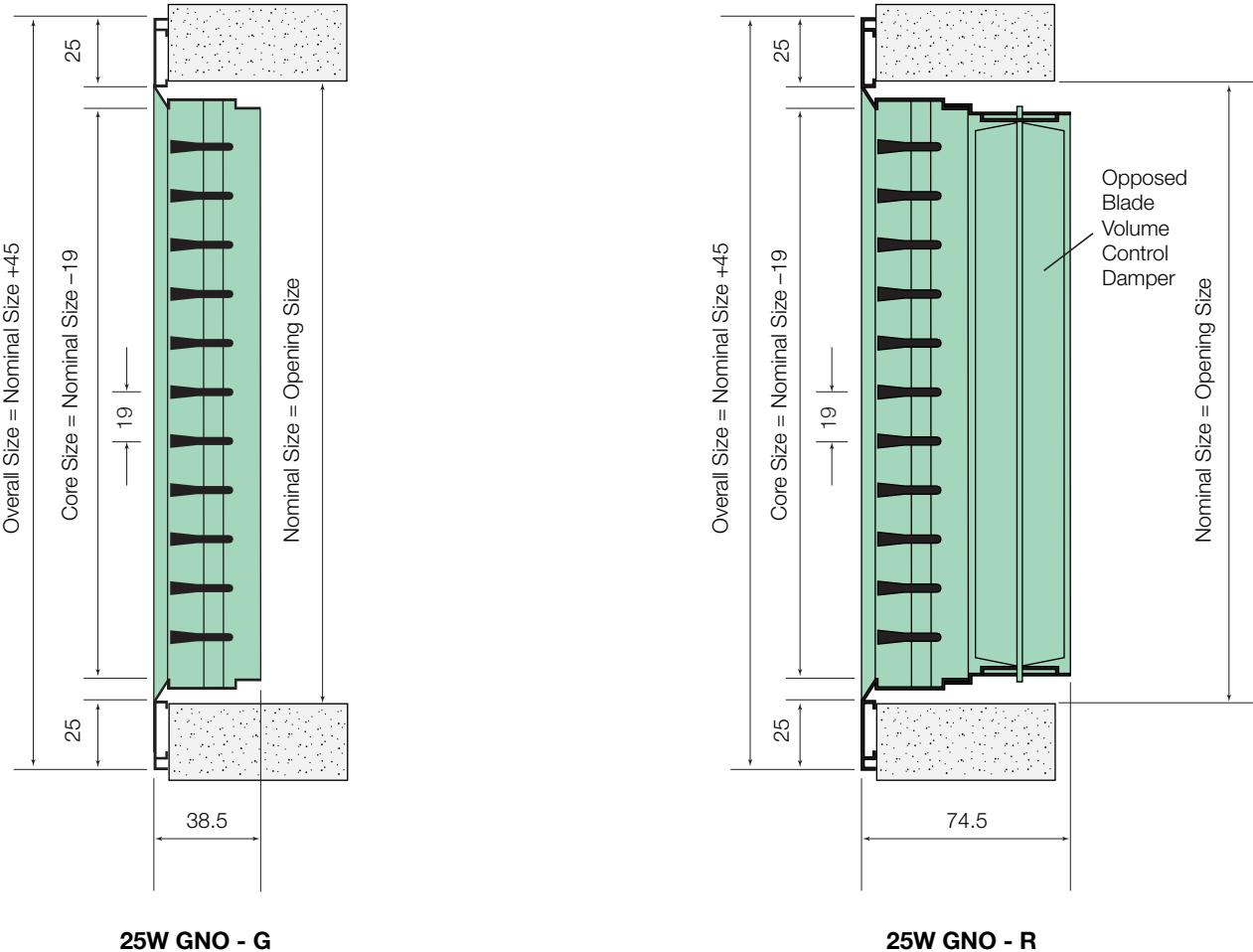

Dimensions

44mm Wide Border Model GN

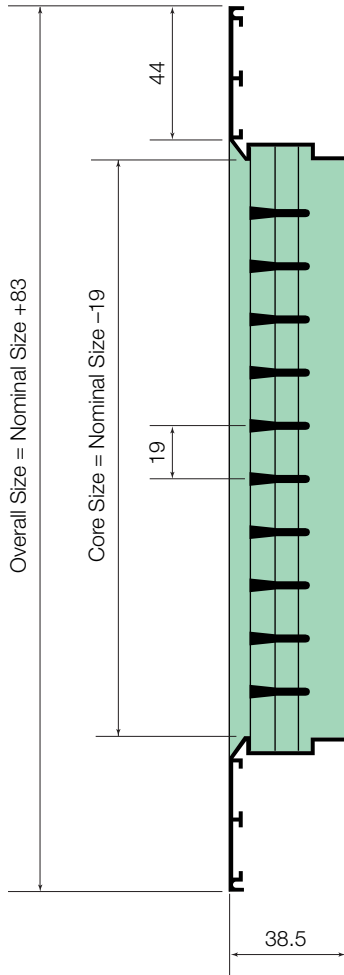

44W - GN0 - G

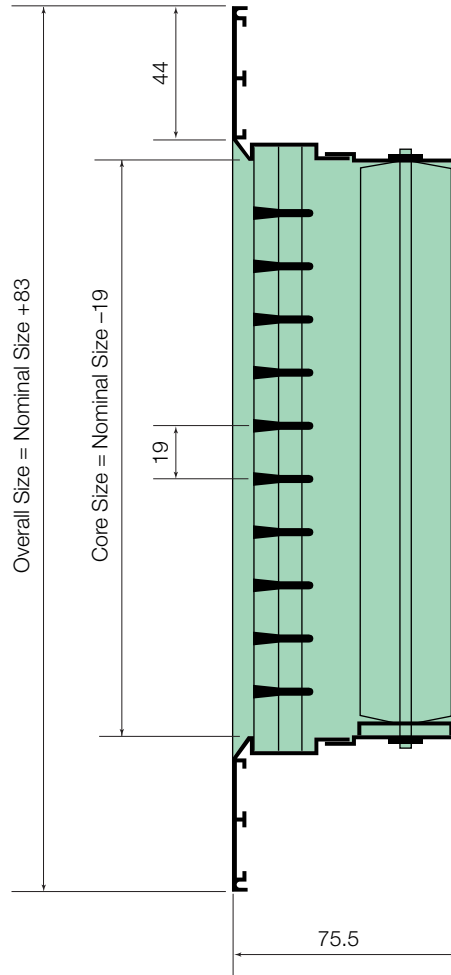

44W - GN0 - R

Performance Guide

Jet Characteristics

1. Determine air volume flow rate per outlet.
2. If a supply application, establish available throw – use Selection Nomogram.
3. Establish required maximum noise and pressure values for exhaust - use Selection Nomogram
4. With a straight edge line across from the litres per second value through values within the maximum parameters established to the pivot line.
5. Retaining the position of intersection at the pivot line, pivot the straight edge until it meets acceptable values of size to its left and right.

Note:

The pivot line represents an area and by maintaining position on this line, widths and heights can be selected of equal area. See note regarding effect of aspect ratio on throw for supply applications.

Fig. 1

Vertically discharging airstreams are affected by temperature and the resulting density difference between the discharging air and ambient air. Throw is also affected by the proximity of surfaces. Use the graph opposite to provide a correction factor to apply to catalogue throws.

Note: The relative temperature values are based on downward discharge - for upward discharge reverse the heating and cooling effect.

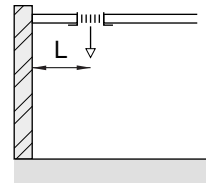

Curve Reference	
X	L = Up to 0.5m
Y	L = More than 2.0m

The Effect of Temperature on Vertical Discharge

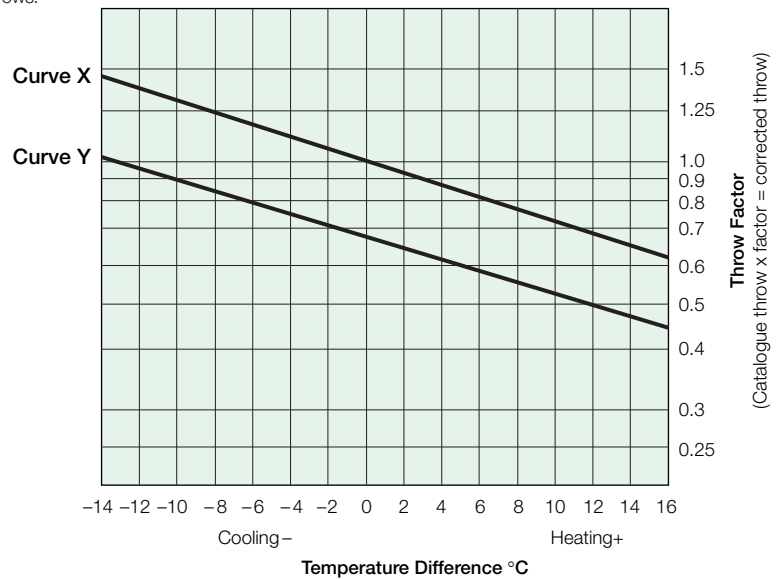

Free Space Supply

In free space horizontal discharge applications, the direction of the air will be dependant on the relative temperature of the primary air to ambient. This can cause unsatisfactory conditioning of the occupied zone and in some cases vertical discharge down or up walls is a more suitable approach. (Please refer to the chart showing the effect of temperature and surface to vertical discharge. Fig.1).

Throw is reduced in free space where there is no ceiling effect or other surface proximity and the reduction for isothermal conditions is 30% from the figures given on the nomogram.

For primary air above or below ambient the throw measured horizontally is affected by the mass and temperature. Fig. 2 illustrates typical centre of jet air patterns, at the same mass and different temperatures.

Aspect Ratio

From the points above it is clear that throw is a complex derived value and another factor which has an effect is the aspect ratio or proportion of the largest nominal dimension to the smallest.

Nomogram figures can be taken for aspect ratios from 1:1 to 2:1 but if the aspect ratio is greater, then the following factors can be applied:

- 3:1 Reduce throw by 5%
- 4:1 Reduce throw by 8%
- 5:1 Reduce throw by 12%

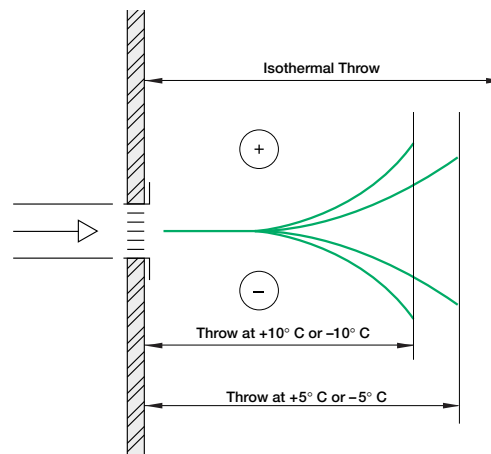

The Effect of Temperature on Free Space Jets

Temperatures are in relation to space ambient

Performance Guide

Selection Procedure

Notes to Selection Data

1. Determine air volume flow rate per outlet.
2. If GNO or GWO supply application, establish available throw.
3. Establish require maximum noise and pressure values - refer to the appropriate nomogram
4. With a straight edge line across from the litres per second value through values within the maximum parameters established to the pivot line.
5. Retaining the position of intersection at the pivot line, pivot the straight edge until it meets acceptable values of size to its left and right.

Note:

The pivot line represents an area and by maintaining position on this line widths and heights can be selected of equal area. See note regarding effect of aspect ratio on throw for supply applications.

Please refer to additional note on Page 1 regarding air jet characteristics under various conditions.

Pressure Loss

The total pressure losses given are for grilles with dampers fitted with the dampers fully open. A 10% reduction of the value can be taken for grilles without dampers.

Sound Levels

Wherever possible we give NR power levels generated by the product. This enables the allowances for room characteristics, surface mounting and multiple outlets from the sound advice leaflet to be taken into account and more accurately predict the sound pressure measured in the occupied space.

The NR power level given includes for a fully open damper. For grilles without dampers 2dB can be subtracted. However, the effect of partly closing the damper for balancing purposes can add significantly to generated noise.

Throw

Throws shown in the catalogue are based on horizontal discharge of cooled air with full attachment of the jet to a flat ceiling close enough above the grille position to enable this condition to occur. For most cases for ceiling effect the grille would be positioned no more than 300mm below the ceiling.

Core area (m²) - Preferred Sizes

Nominal Height	Nominal Width - mm														
	mm	150	200	250	300	350	400	500	600	700	800	900	1000	1100	1200
100	.0077	.0110	.0143	.0176	.0209	.0242	.0308	.0374	.0440	.0506	.0572	.0638	.0704	.0770	
150	.0136	.0193	.0251	.0309	.0367	.0425	.0541	.0657	.0773	.0889	.1005	.1121	.1237	.1353	
200		.0276	.0359	.0442	.0525	.0608	.0774	.0940	.1106	.1272	.1438	.1604	.1770	.1936	
250			.0467	.0574	.0683	.0791	.1007	.1223	.1439	.1655	.1871	.2087	.2303	.2519	
300				.0708	.0841	.0974	.1240	.1506	.1772	.2038	.2304	.2570	.2836	.3102	
400						.1340	.1706	.2072	.2438	.2804	.3170	.3536	.3902	.4268	
500							.2172	.2638	.3104	.3570	.4036	.4502	.4968	.5434	
600									.3204	.3770	.4336	.4902	.5468	.6034	.6600

Free Area Factors:

GNO = 0.85

GWO = 0.70

Based on 300 x 300 nominal size, the figures above may vary by 5% dependent on grille size.

Models NB, WB – Nomogram

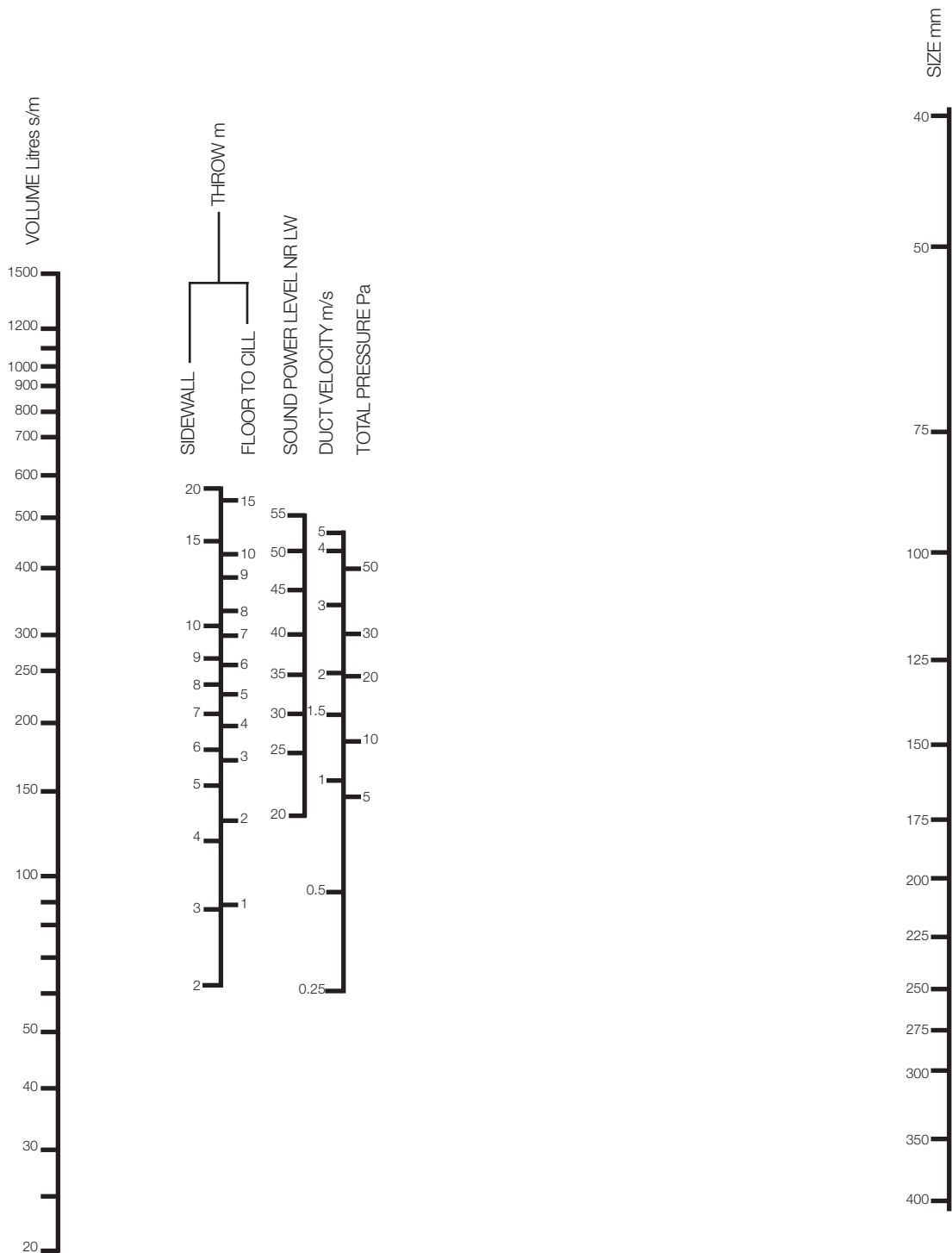

Values shown are for Model WB. For NB apply correction factors as shown.

NB Correction Factors

Throw
x 0.8

Sound Power
- 2dB

Throw
x 0.8

All values include for fitted opposed blade dampers.

Throw based on 10° cooling to terminal velocity of 0.25m/s.

Side wall throw assumes flat ceiling not more than 0.5m above grille centre line.

Models GNO and GWO – Nomogram

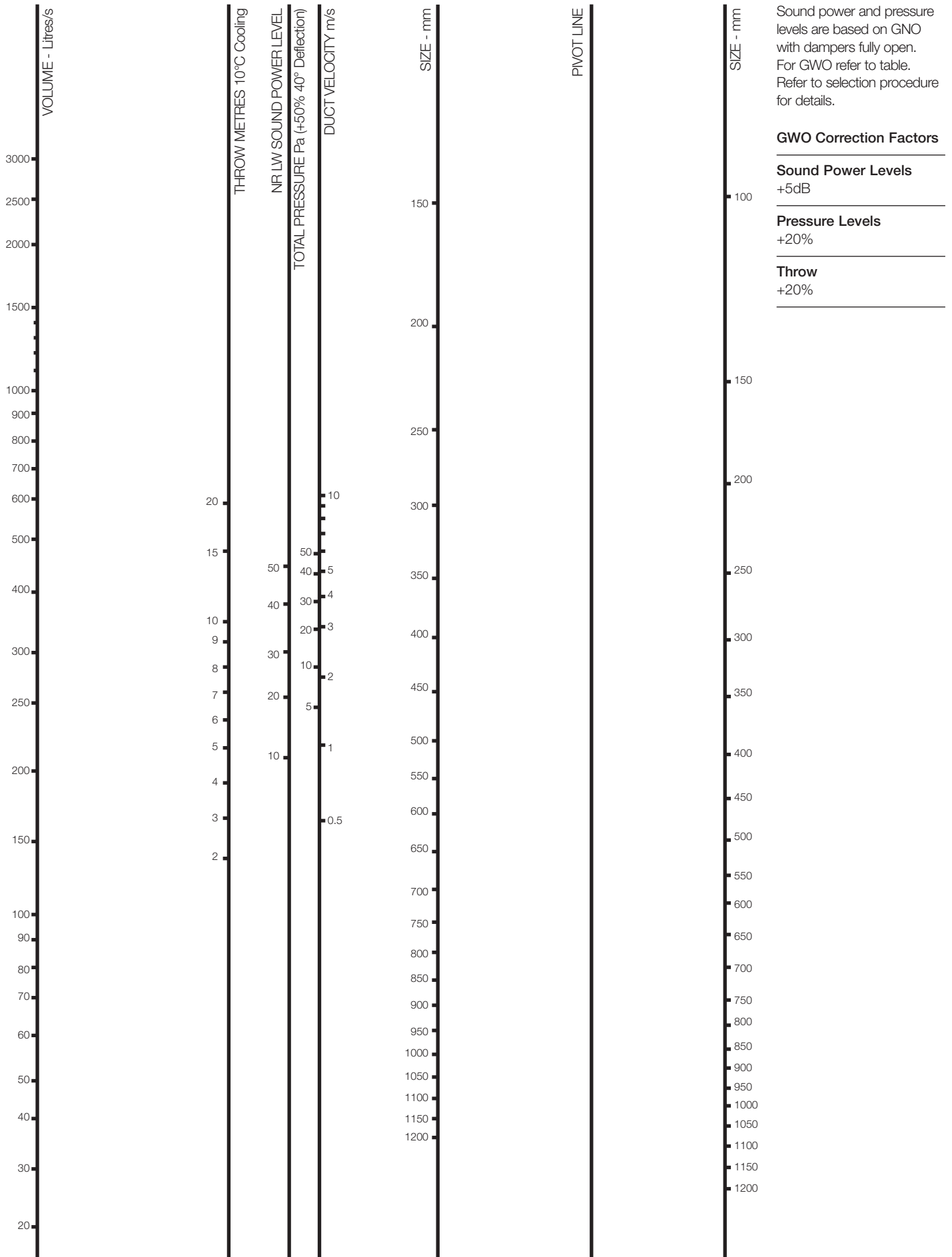

Installation Guide

Type F1

Standard face countersunk holes for screw fixing.

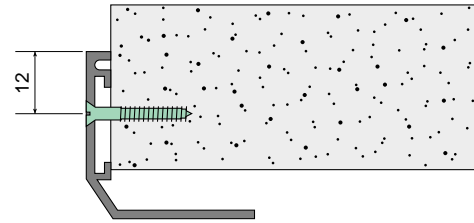

Type F2

Optional spring clips.

Note:

For satisfactory fixing require accurately formed opening or duct with firm sides. Not suitable for ceiling or high sidewall installation.

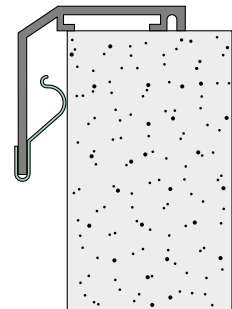

Type F4

Optional rear strap.

Note:

Mating strap by others.

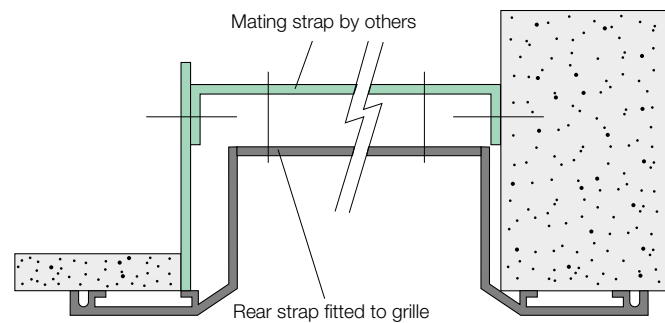

Type F6

Optional rear strap plus mating 'U' bracket.

Note:

Hemmed duct by others or plenums by us.

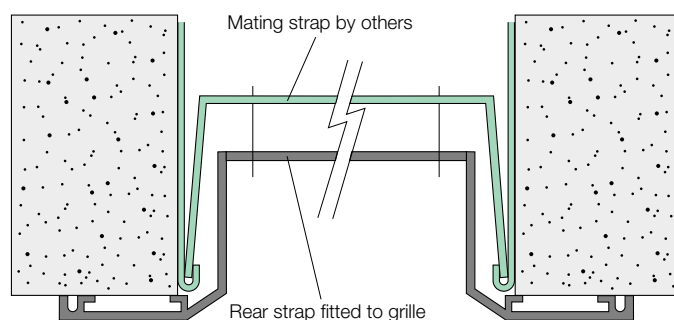

Type F8 - Ceiling Alignment Clip Fixing

(Details of ceiling system and clip to be supplied).

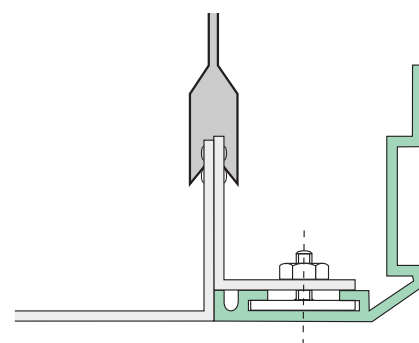

Removable Core Details

Spring Terry Clip Arrangement Suitable for use with Models G45 NB, GN, WB and GW

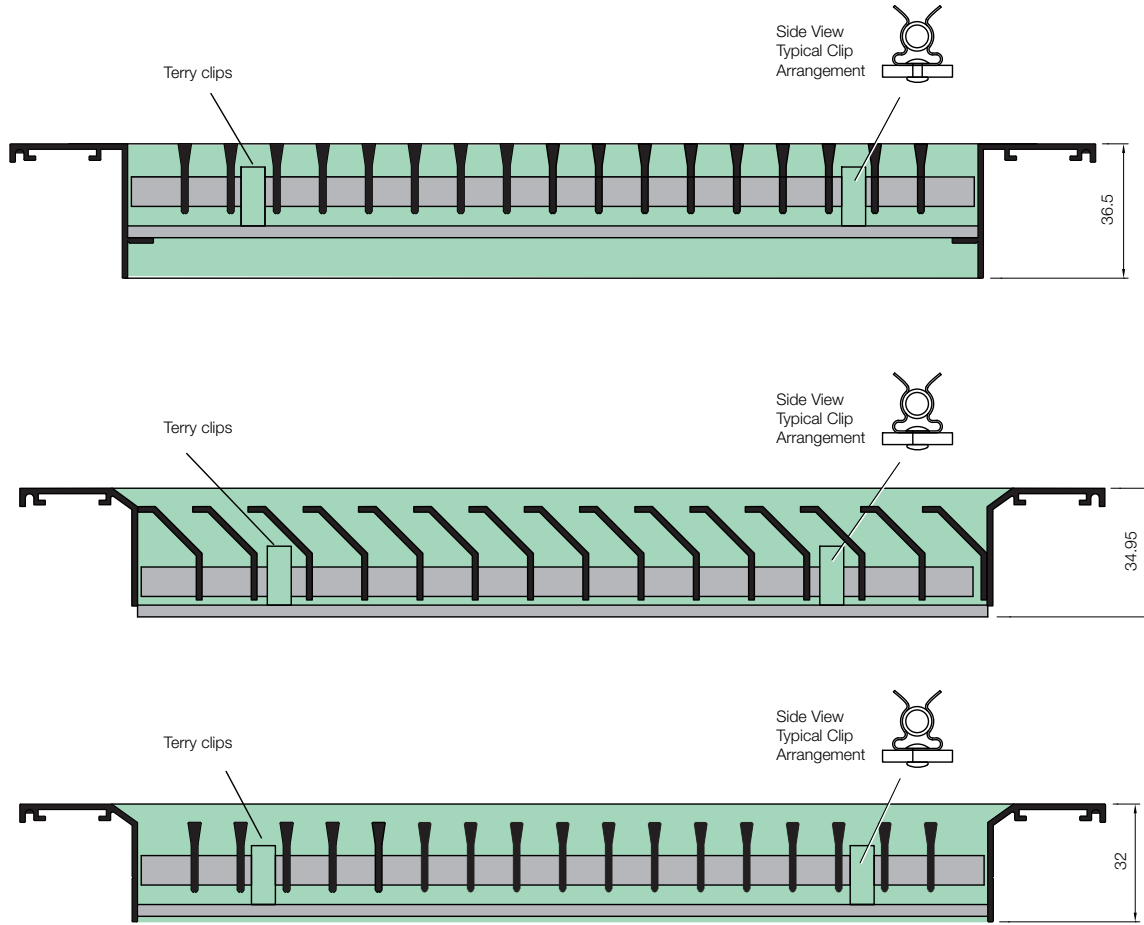

Pullsert Arrangements. Suitable for use with models NB, GN, WB and GW.

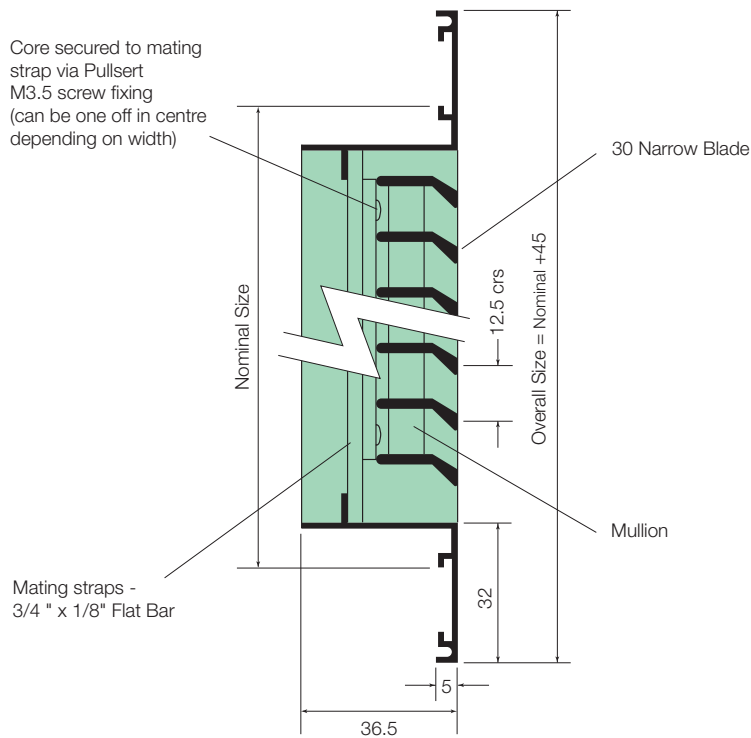

Model 32W - NB30G - RC

Ordering Information

Example

Flange Style 25W	Model CB2L	Damper R	Fixing F0	Finish 3	Size
<p>20W – 20mm flat surface flange having mitred and welded corners.</p> <p>20C – 20mm flat surface flange having mitred and mechanically cleated corners.</p> <p>25W – 25mm flat surface flange having mitred and welded corners.</p> <p>25C – 25mm flat surface flange having mitred and mechanically cleated corners.</p> <p>32W – 32mm flat surface flange having mitred and welded corners.</p> <p>44W – 44mm wide flat surface flange having mitred and welded corners (Model EC only).</p>	<p>Curved Blade Ceiling Grilles</p> <p>25W, 25C CB1L curved blade ceiling grille having 1 way air pattern with blades running parallel to the longest side.</p> <p>25W, 25C CB1S curved blade ceiling grille having 1 way air pattern with blades running parallel to the shortest side.</p> <p>25W, 25C CB2L curved blade ceiling grille having 2 way air pattern with blades running parallel to the longest side.</p> <p>25W, 25C CB2S curved blade ceiling grille having 2 way air pattern with blades running parallel to the shortest side.</p> <p>25W, 25C CB2S (LH) curved blade ceiling grille having a 2 way corner air pattern with 1 set of blades running parallel to the shortest side and 1 set at right angles left handed.</p> <p>25W, 25C CB2S (RH) curved blade ceiling grille having a 2 way corner air pattern with 1 set of blades running parallel to the shortest side and 1 set at right angles right handed.</p> <p>25W, 25C CB3L curved blade ceiling grille having 3 way air pattern with outer blades running parallel to the longest side.</p> <p>25W, 25C CB3S curved blade ceiling grille having 3 way air pattern with outer blades running parallel to the shortest side.</p> <p>25W, 25C CB3S (EQ) curved blade ceiling grille having a 3 way air pattern with the 2 outer blade sets running parallel to the shortest side with an equal size 3rd set located in the centre.</p> <p>25W, 25C CB4L curved blade ceiling grille having 4 way air pattern with outer blades running parallel to the longest side.</p> <p>25W, 25C CB4S curved blade ceiling grille having 4 way air pattern with outerblades running parallel to the shortest side.</p> <hr/> <p>Single Deflection Grilles</p> <p>25W, 25C SDH single deflection grille with a one set of horizontal blades.</p> <p>25W, 25C SDV single deflection grille with a one set of vertical blades.</p> <hr/> <p>Double Deflection Grilles</p> <p>25W, 25C DDH double deflection grille with one set of front horizontal and one set of rear vertical blades.</p> <p>25W, 25C DDV double deflection grille with one set of front vertical and one set of rear horizontal blades.</p> <hr/> <p>Egg Crate Grille</p> <p>25W, 25C 44W ECG egg crate grille with a fixed core.</p> <p>25W, 25C ECG-RC egg crate grille with a removable core.</p> <hr/> <p>Perforated Grille</p> <p>25W, 25C 44W PG perforated grille with a fixed core.</p> <hr/> <p>45° Fixed Blade</p> <p>25W, 25C 44W FBG45 45° fixed blade grille with a 1 way core. (State separately if 2 way core required).</p> <hr/> <p>Non Vision Grille</p> <p>25W, 25C NVG non-vision grille.</p> <p>25W, 25C NVG-MF non-vision grille with a standard matching flange.</p> <p>25W, 25C NVG-DF non-vision grille with a deep matching flange.</p> <hr/> <p>Bar Grilles</p> <p>20W, 20C, 25W, 25C, 32W, 44W NB0 narrow blade bar grille having 0° deflection, 3.5mm blade on 12.5mm pitch.</p> <p>20W, 20C, 25W, 25C, 32W, 44W NB15 narrow blade bar grille having 15° deflection, 3.5mm blade on 12.5mm pitch.</p> <p>20W, 20C, 25W, 25C, 32W, 44W NB30 narrow blade bar grille having 30° deflection, 3.5mm blade on 12.5mm pitch.</p> <p>20W, 20C, 25W, 25C, 32W, 44W GN0 narrow blade bar grille having 0° deflection, 3.5mm blade on 19mm pitch.</p> <p>20W, 20C, 25W, 25C, 32W, 44W GN15 narrow blade bar grille having 15° deflection, 3.5mm blade on 19mm pitch.</p> <p>20W, 20C, 25W, 25C, 32W, 44W GN30 narrow blade bar grille having 30° deflection, 3.5mm blade on 19mm pitch.</p> <hr/> <p>20W, 20C, 25W, 25C, 32W, 44W WB0 wide blade bar grille having 0° deflection, 6.5mm blade on 14mm pitch.</p> <p>20W, 20C, 25W, 25C, 32W, 44W WB15 wide blade bar grille having 15° deflection, 6.5mm blade on 14mm pitch.</p> <p>20W, 20C, 25W, 25C, 32W, 44W WB30 wide blade bar grille having 30° deflection, 6.5mm blade on 14mm pitch.</p> <p>20W, 20C, 25W, 25C, 32W, 44W WB15 wide blade bar grille having 15° deflection, 6.5mm blade on 14mm pitch.</p> <hr/> <p>20W, 20C, 25W, 25C, 32W, 44W GW0 wide blade bar grille having 0° deflection, 6.5mm blade on 19mm pitch.</p> <p>20W, 20C, 25W, 25C, 32W, 44W GW15 wide blade bar grille having 15° deflection, 6.5mm blade on 19mm pitch.</p>	<p>F0 – No fixing (fixing BY OTHERS).</p> <p>F1 – Countersunk Screw Holes in Flange (Standard).</p> <p>F2 – Spring Clips (not recommended for ceiling or high sidewall installation).</p> <p>F4 – Rear strap (concealed behind grille core) mating strap BY OTHERS.</p> <p>F6 – Rear strap and Mating ‘U’ bracket (requires hemmed duct BY OTHERS).</p> <p>F8 – Ceiling alignment clip. (Note: details of ceiling type and clip must be provided).</p> <p>F10 – Removable core spring terry clip.</p>	<p>Width x Height</p>		

G – Grille only.

R – Grille with OBD fitted.

0 – Mill extruded aluminium.

2 – Silver (RAL9006) polyester powder coat.

3 – White (RAL9010) 20% polyester powder coat.

4 – Black (RAL9005) polyester powder coat.

5 – Brushed (Linished) natural aluminium face surfaces, 32 mm frame only.

6 – Special polyester powder coat finish. (Please state separately the RAL colour reference and finish type required).

Important Note: If the overall size is critical then it must be clearly stated on the order. All orders must be addressed to AIR DIFFUSION, Ruskin Air Management Limited.

Fixed and Removable Core - Bar Grilles Only.
 To denote a Fixed Core bar grille FC must be added to the Model type (e.g. NB0FC) alternatively to denote a removable core bar grille RC must be added to the Model type (e.g. NB0RC).

Product Range

Swirl, Displacement and High Induction Diffusers



Circular Diffusers and Air Valves



Perforated and Louvre Face Ceiling Diffusers



Slot and Fixed Blade Diffusers



Cylinder and Jet Nozzle Diffusers



Floor Grilles

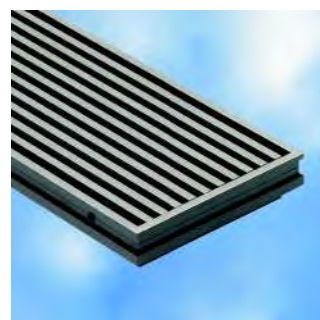
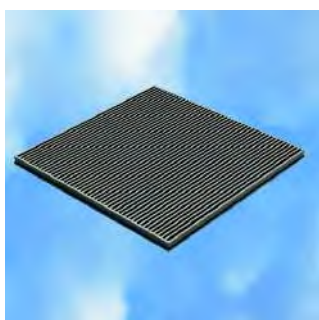

Product Range

Linear Grilles

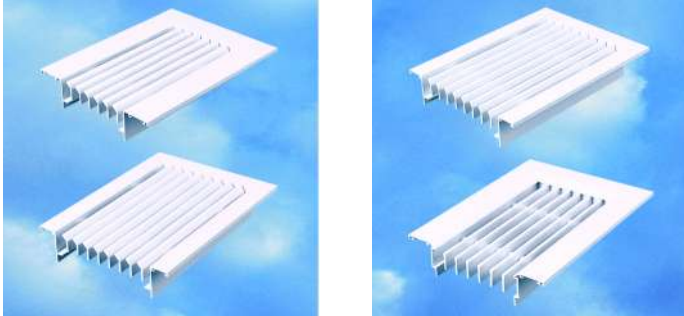

Wall and Ceiling Grilles



External Louvres



Miscellaneous



- Swirl, Displacement and High Induction Diffusers
- Perforated and Louvre Face Ceiling Diffusers
- Slot and Fixed Blade Linear Diffusers
- Cylinder and Jet Nozzle Diffusers
- Circular Diffusers and Air Valves
- Floor Grilles
- Linear Bar Grilles
- Grilles
- External Louvres
- Miscellaneous

**Ruskin Air Management Limited
is a BS EN ISO 9000 registered
company.**

The statements made in this brochure or by our representatives in consequence of any enquiries arising out of this document are given for information purposes only. They are not intended to have any legal effect and the company is not to be regarded as bound thereby. The company will only accept obligations which are expressly negotiated for and agreed and incorporated into a written agreement made with its customers.

Due to a policy of continuous product development the specification and details contained herein are subject to alteration without prior notice.

**Comprehensive and detailed information
is available for all Air Diffusion products.
Visit our website at www.air-diffusion.co.uk**

Ruskin Air Management Limited



Stourbridge Road, Bridgnorth, Shropshire,
WV15 5BB England.
Tel: 01746 761921
Fax: 01746 760127
Email: sales@air-diffusion.co.uk
Website: www.air-diffusion.co.uk

Air Diffusion

Grilles Diffusers Louvres Chilled Beams