

Linear Bar Grilles

Models NB, WB, GN and GW

Features

- Aluminium Construction
- 4 Model Types
- 7 Flange Styles
- 0°, 15° and 30° Deflection Blades
- Mitred Corner Sections
- Curved Sections
- Access Panels
- Matching Plenum Boxes

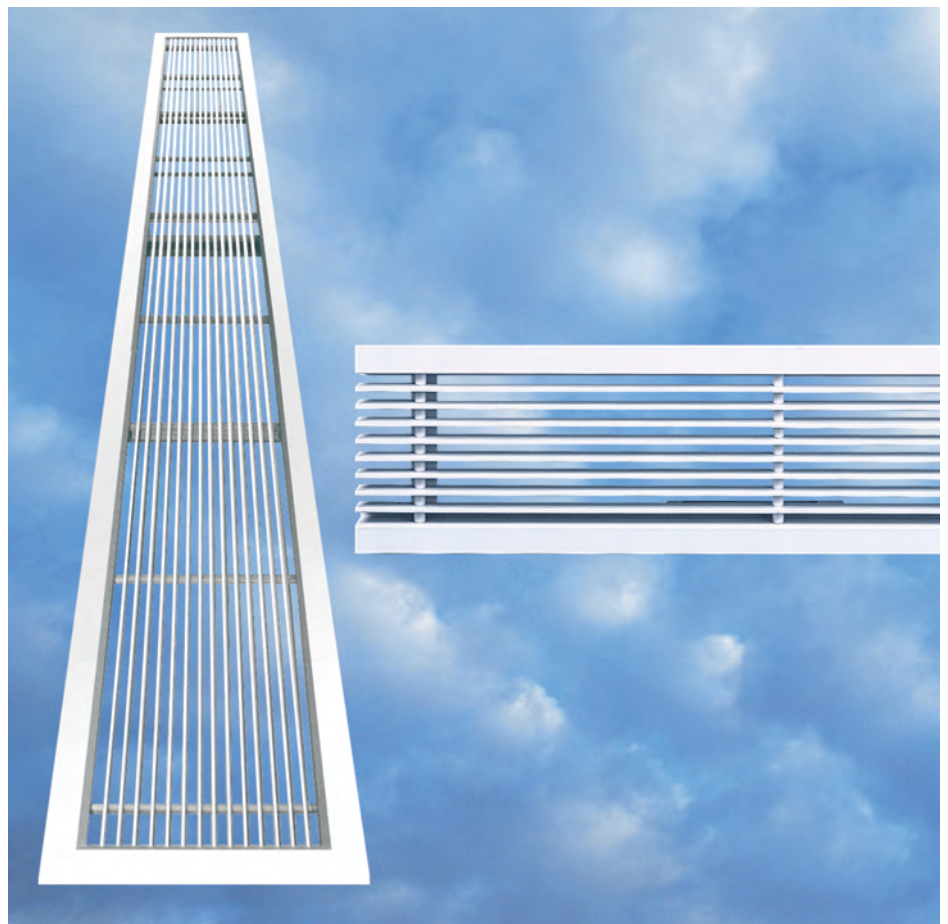

Air Diffusion

Grilles Diffusers Chilled Beams

Ruskin Air Management Limited
www.ruskinuk.co.uk

Contents

	Page
Introduction	Page 3
Flange Styles	Page 4
Mitred Corners and Access Panels	Page 5
Curved Sections	Page 6
Models NB and WB Specifications	Page 7
Models NB and WB Selection Procedure	Page 8
Models NB and WB Selection Nomogram	Page 9
Models NB and WB Dimensions	Page 10 and 11
Models GN and GW Specifications	Page 12
Models GN and GW Selection Procedure	Page 13
Models GN and GW Selection Nomogram	Page 14
Models GN and GW Dimensions	Page 15
Fixing Details	Page 16
Removable Core Details	Page 17 and 18
Ordering Information (Diffusers)	Page 19
Plenum Boxes	Page 20, 21 and 22
Ordering Information (Plenums)	Page 22
Product Range	Page 23

Introduction

The Air Diffusion range of fixed blade Linear Bar Grilles includes four model types to satisfy most applications. Each model type is manufactured from robust extruded aluminium sections to ensure the finished product offers functional strength and performance that also gives an attractive and aesthetically pleasing appearance.

Model NB narrow blade bar type linear grille incorporates a 3.5mm wide blade on a 12.5mm pitch, with blades available in 3 deflection angles 0°, 15° or 30°.

Model WB wide blade bar type linear grille incorporates a 6.5mm wide blade on a 15.5mm pitch, with blades available in 2 deflection angles 0° or 15°.

Model GN narrow blade bar type linear grille incorporates a 3.5mm wide blade on a 19mm pitch, with blades available in 3 deflection angles 0°, 15° or 30°.

Model GW wide blade bar type linear grille incorporates a 6.5mm wide blade on a 19mm pitch, with blades available in 2 deflection angles 0° or 15°.

A total of seven different flange styles are available including tegular, bevel, 20mm, 25mm or 32mm wide surface mounting flange, alternatively an internal or external reverse angle flange may be provided.

The versatility of the range is demonstrated by the ability to offer curved sections in either a vertical or horizontal plane, mitred corner sections, for sidewalls, soffits, cills or ceilings and finally for added convenience hinged access panels to allow easy accessibility for controls or maintenance.

Standard colours are White RAL9010 (20% gloss) or Silver RAL9006 with a wide variety of alternative finishes also available on request.

Matching plenum boxes can be supplied to guarantee the performance of the linear bar grille and plenum box, including a correctly sized spigot entry. An optional opposed blade damper may also be supplied fitted to the grille, if required.

The Models NB, WB, GN and GW may be used for either supply or extract systems and typically are suitable for installation in Shops, Showrooms, Hotels, Conference Rooms, Offices, Reception Areas, Sports Halls and Leisure Centres.

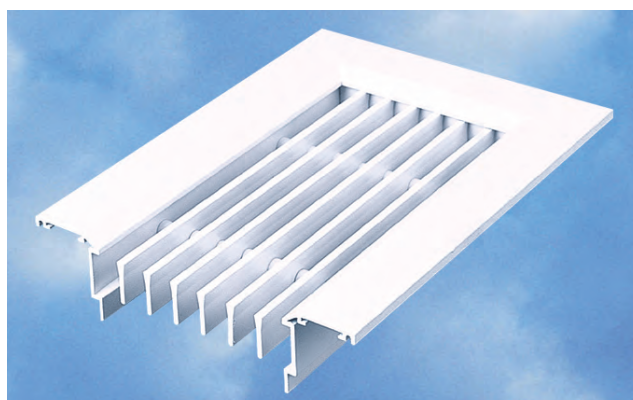
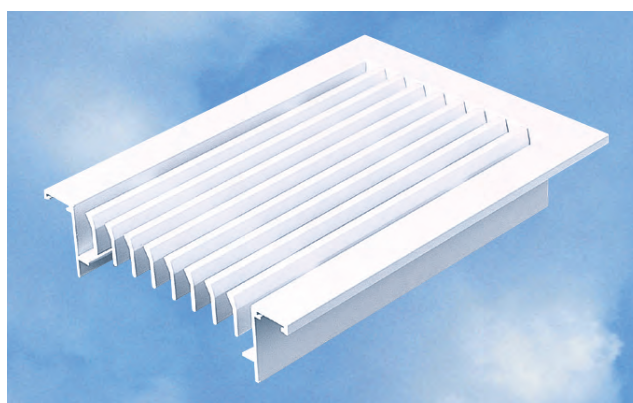
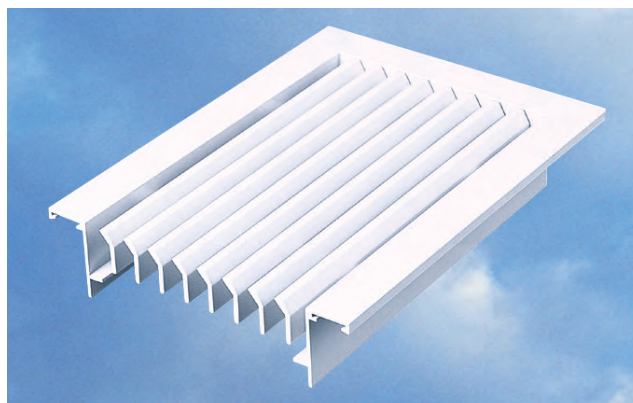
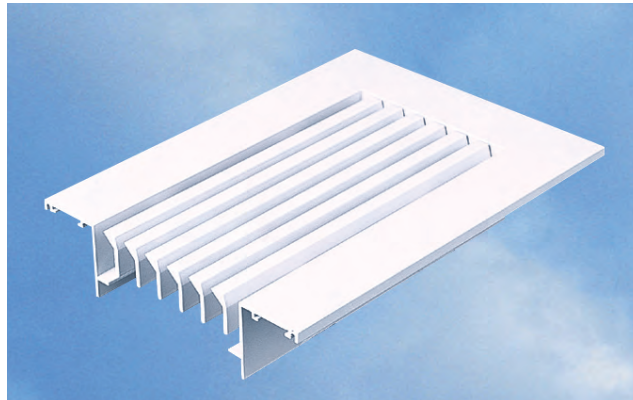

Flange Styles

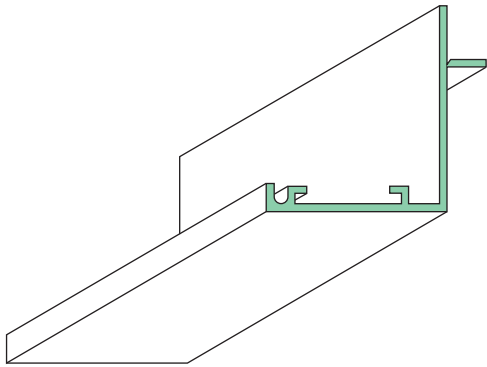
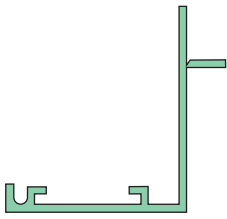

32mm

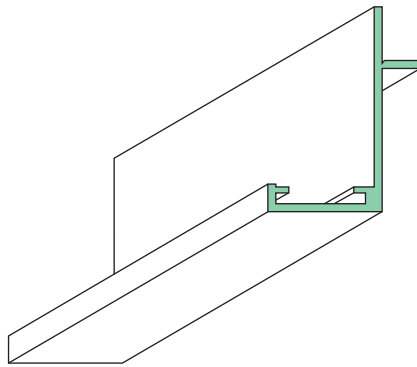
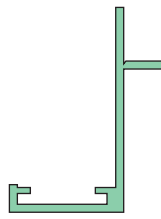

20mm

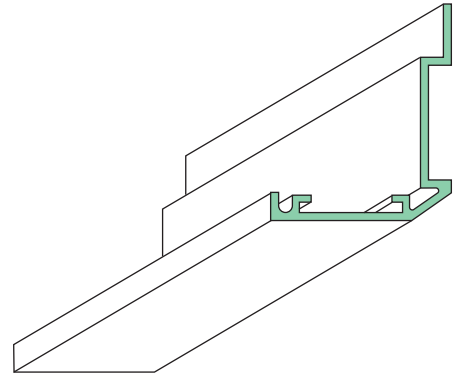
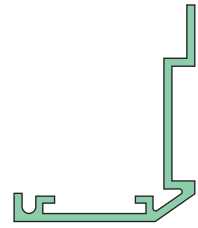

25mm

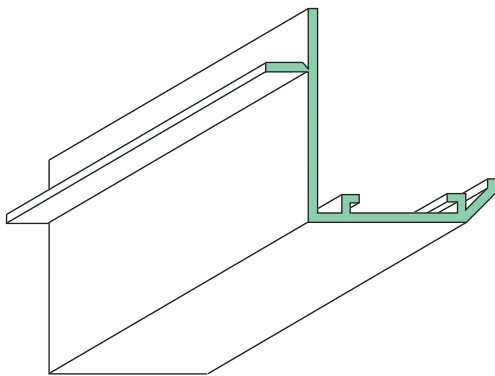
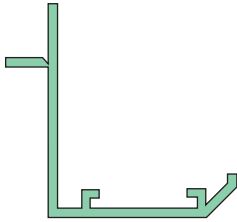

27mm Bevel

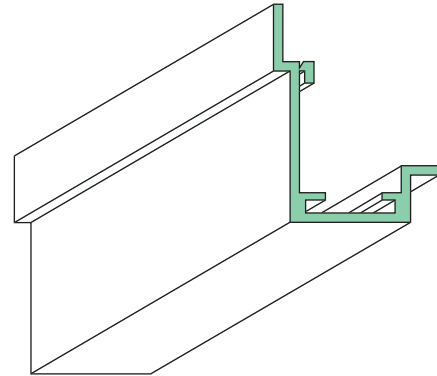
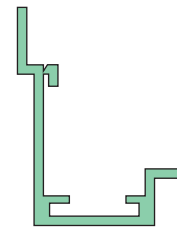

8mm Tegular

Reverse Angle Flange

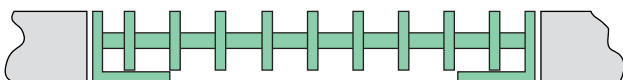

Internal Reverse Angle Flange

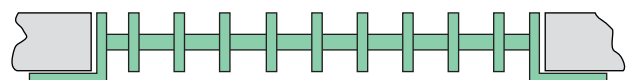

External Reverse Angle Flange

Mitre Corners and Access Panels

Mitre Corners

Mitred Corners are available and are manufactured to order. Mitres can be cut to any angle. Available in three styles for cill or sidewall.

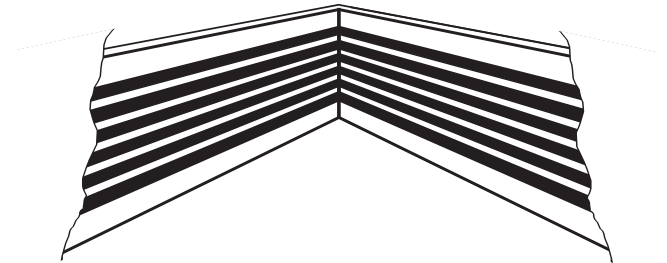
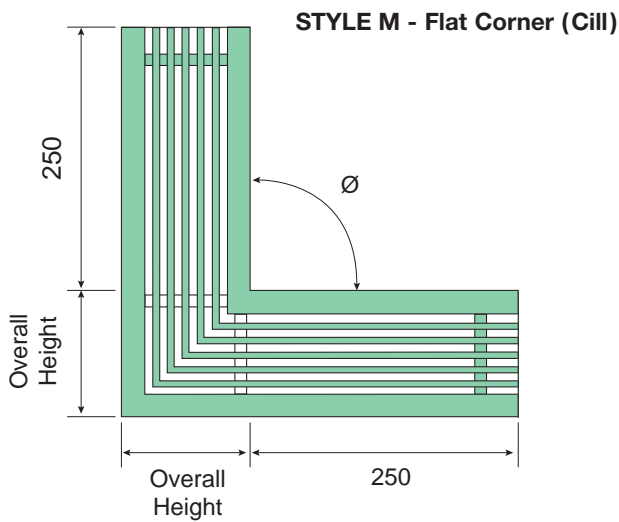

STYLE M INTERIOR - Inside Corner (Sidewall)

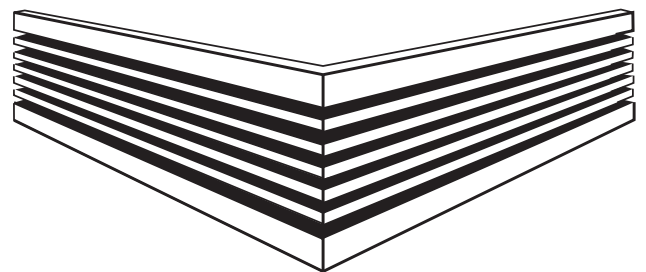

STYLE M EXTERIOR - Outside Corner (Sidewall)

Hinged Access Panels

Access Panels

Hinged Access Panels are standard length 150mm long. Access Panels of other lengths/designs can be supplied if requested.

When ordering, state either Right Hand (RH) or Left Hand (LH) position and if linear has a blade deflecting the airflow direction. (See sketch below).

Hinged Access Panel Type 1

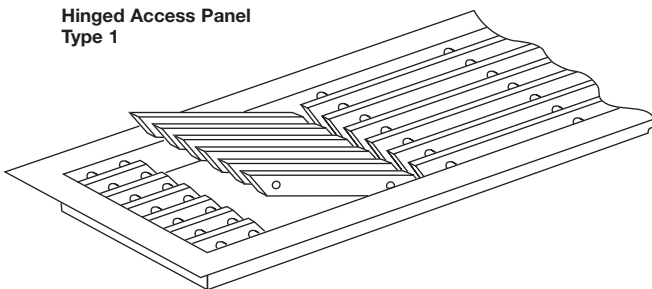

Hinged Access Panel Type 2

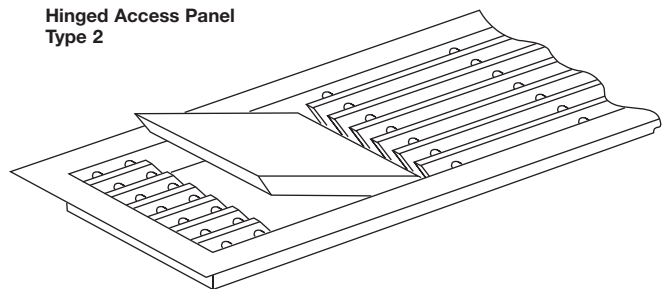

Example

Order:
HAP - Type 1 - LH

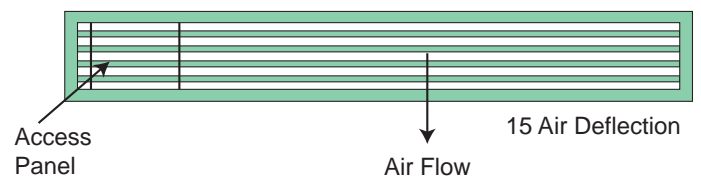

Curved Sections



Curved Linear Grilles

Information required for manufacture of curved grilles:

- A = Nominal Opening Size of Chord
- B = Arc
- C = Radius

Curved Grilles are supplied with 0° Deflection Blade.
Where possible, a template should be supplied so that true radius can be supplied to fit opening.

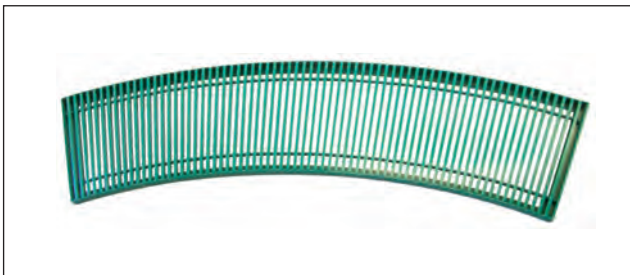
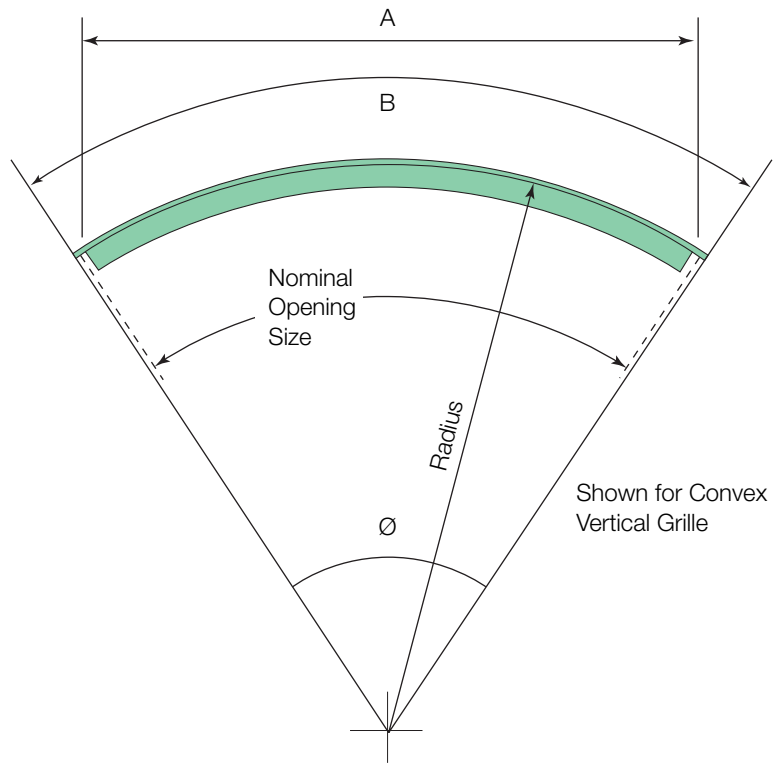

Example

Horizontal Grille can be supplied as core only or with flanges.

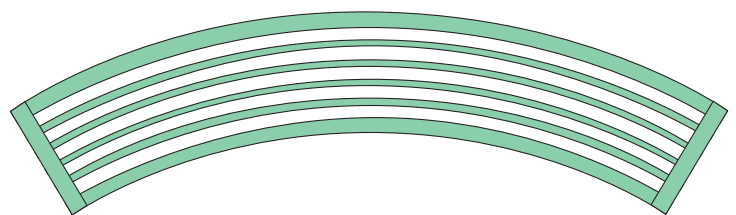

Horizontal Blades

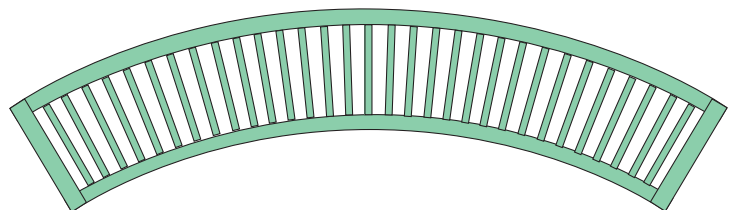

Vertical Blades

Models NB and WB Specifications

Specification

Materials

Extruded aluminium throughout.

Finish

Standard

White RAL 9010, or Silver RAL 9006 stove enamel.

Optional

See Ordering Information section for details.

Flanges

20mm, 25mm and 32mm plus tegular, bevel, and two reverse angle frames. Also, core only can be supplied.

Fixings

Standard

Front face screw fixing through border on 25mm and 32mm. Spring clip or secret fix on 20mm.

Optional

See Ordering Information section for details.

Mullions

Formed from 8mm tubular aluminium at approx. 300mm spacing.

Continuous Line

Maximum single unit length 1800mm. Above this size linear runs are supplied in multiple units for butt joining, flange alignment strips are supplied to ensure continuous line appearance.

Dampers

If specified - opposed blade type. Available on widths of 100mm and above. Aluminium construction. Concealed screw cam operation through grille face. Mill finish as standard, other finishes available to special order.

Access Panels

Pivoted sections are available to order to give access to fan coil switches and control valves, etc.

Mitred Corners

Standard

Internal arm lengths 250mm at 90°.

Special Order

Other angles, arm length to suit. A template or drawing will usually be required.

Sizes Available

Length

See Continuous Line.

Height

Up to a maximum height of 600mm, increments of 25mm are offered. Although most height increments are available.

Special Requirements

Linear bar grilles can be supplied to suit curved areas. These can only be supplied with 0° deflection blades.

Grilles can be concave or convex. Dampers can not be fitted to rear of curved grilles. Linear blade grilles priced on request to Sales Office.

Core only linear bar grilles can be supplied - these have recessed nuts or screws and can be supplied with secret strap fixing. Prices on request to Sales Office.

Special Finish

Fixed blade linear grilles can be supplied in a bright polished and anodised finish either brass or silver. Prices on request to Sales Office.

Linear bar grilles can be supplied in solid brass. These can only be supplied with 0° deflection of the blade. Blade widths are 3mm or 6mm.

Blanking Plates

Blanking plates can be supplied for non-active sections of bar grilles. These plates would be painted matt black. Advise at time of order requirements of blanking plates.

Access Panels

Linear bar grilles can be supplied with access doors either as core sections or solid panel. State requirement at time of order.

Hinged and Removable Cores

To enable access behind linear bar grilles, hinged cores can be fitted. The cores can be secured with either budget locks or screw fixed. In addition removable cores are also available.

Safety Cords

Safety cords can be fitted to loose cores. State if required at time of quotation/order.

Ordering

Always specify opening {length x opening height} - this is the nominal size of the grille. Fitting tolerances will be deducted by us in manufacture. See Ordering Information section for full details of ordering procedure.

Models Available

NB0

Fixed 3.5mm blade linear grille having blades at 0° deflection.

NB15

Fixed 3.5mm blade linear grille having blades at 15° deflection.

NB30

Fixed 3.5mm blade linear grille having blades at 30° deflection.

WB0

Fixed 6.5mm blade linear grille having blades at 0° deflection.

WB15

Fixed 6.5mm blade linear grille having blades at 15° deflection.

G

Grille Only.

R

Grille with Opposed Blade Damper.

Special Applications

A set of adjustable vertical blades can be fitted behind the grille core to provide a wider angle discharge.

For details please refer to Sales Office.

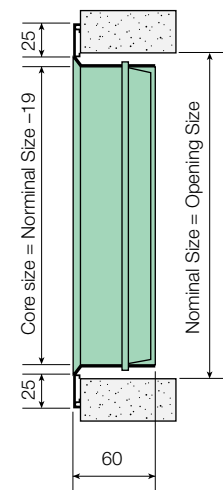

Selection Procedure Jet Characteristics

1. Determine air volume flow rate per outlet.
2. If a supply application, establish available throw - use Selection Nomogram.
3. Establish required maximum noise and pressure values for exhaust - use Selection Nomogram
4. With a straight edge line across from the litres per second value through values within the maximum parameters established to the pivot line.
5. Retaining the position of intersection at the pivot line, pivot the straight edge until it meets acceptable values of size to its left and right.

Note:
The pivot line represents an area and by maintaining position on this line, widths and heights can be selected of equal area. See note regarding effect of aspect ratio on throw for supply applications.

Fig. 1

Vertically discharging airstreams are affected by temperature and the resulting density difference between the discharging air and ambient air. Throw is also affected by the proximity of surfaces. Use the graph opposite to provide a correction factor to apply to catalogue throws.

Note: The relative temperature values are based on downward discharge - for upward discharge reverse the heating and cooling effect.

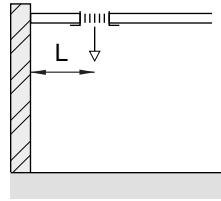

Curve Reference

X	L = Up to 0.5m
Y	L = More than 2.0m

The Effect of Temperature on Vertical Discharge

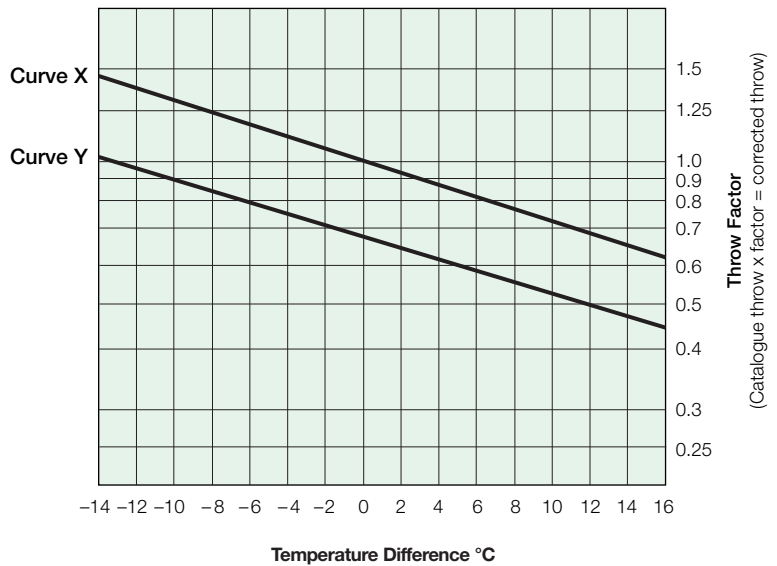

Free Space Supply

In free space horizontal discharge applications, the direction of the air will be dependant on the relative temperature of the primary air to ambient. This can cause unsatisfactory conditioning of the occupied zone and in some cases vertical discharge down or up walls is a more suitable approach. (Please refer to the chart showing the effect of temperature and surface to vertical discharge. Fig.1).

Throw is reduced in free space where there is no ceiling effect or other surface proximity and the reduction for isothermal conditions is 30% from the figures given on the nomogram.

For primary air above or below ambient the throw measured horizontally is affected by the mass and temperature. Fig. 2 illustrates typical centre of jet air patterns, at the same mass and different temperatures.

Aspect Ratio

From the points above it is clear that throw is a complex derived value and another factor which has an effect is the aspect ratio or proportion of the largest nominal dimension to the smallest.

Nomogram figures can be taken for aspect ratios from 1:1 to 2:1 but if the aspect ratio is greater, then the following factors can be applied:

- 3:1 Reduce throw by 5%
- 4:1 Reduce throw by 8%
- 5:1 Reduce throw by 12%

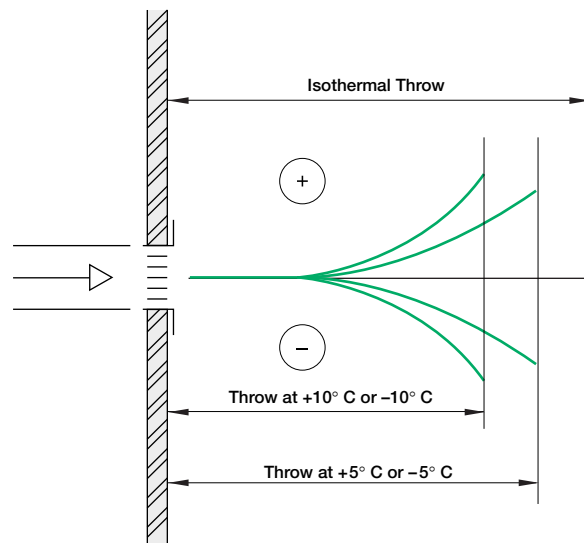

The Effect of Temperature on Free Space Jets

Temperatures are in relation to space ambient

Models NB/NBR, WB/WBR Selection Nomogram

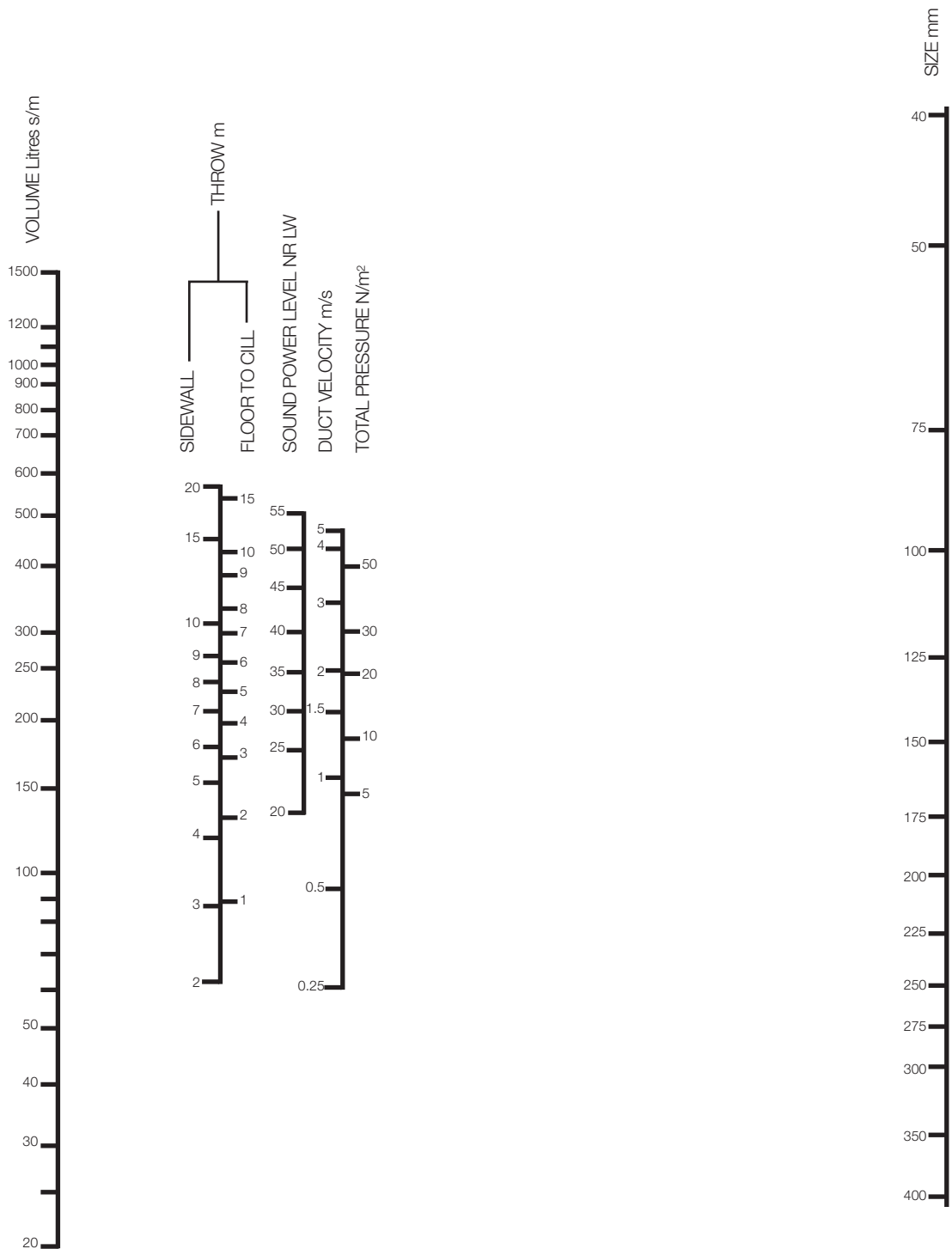

Values shown are for Model WB. For NB apply correction factors as shown below.

NB Correction Factors		
Throw	Sound Power	Total Pressure
x 0.8	- 2db	x 0.8

All values include for fitted opposed blade dampers.
 Throw based on 10° cooling to terminal velocity of 0.25m/s.
 Side wall throw assumes flat ceiling not more than 0.5m above grille centre line.

Dimensions Models NB and WB

20mm Flange

Not available with Flange Fixing Holes

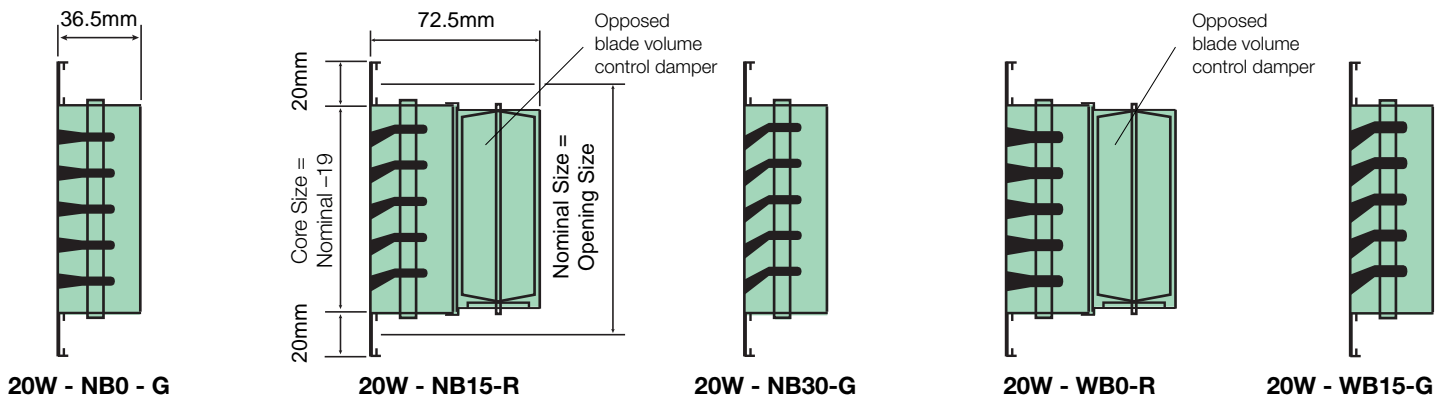
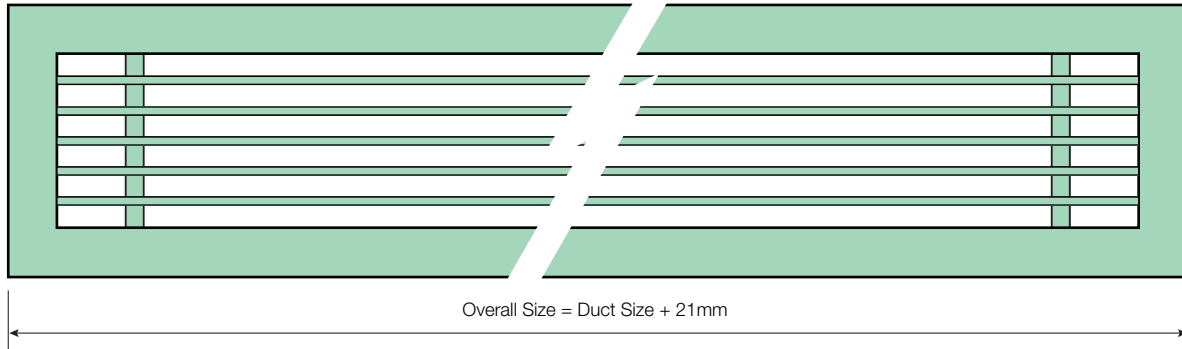

25mm Flange

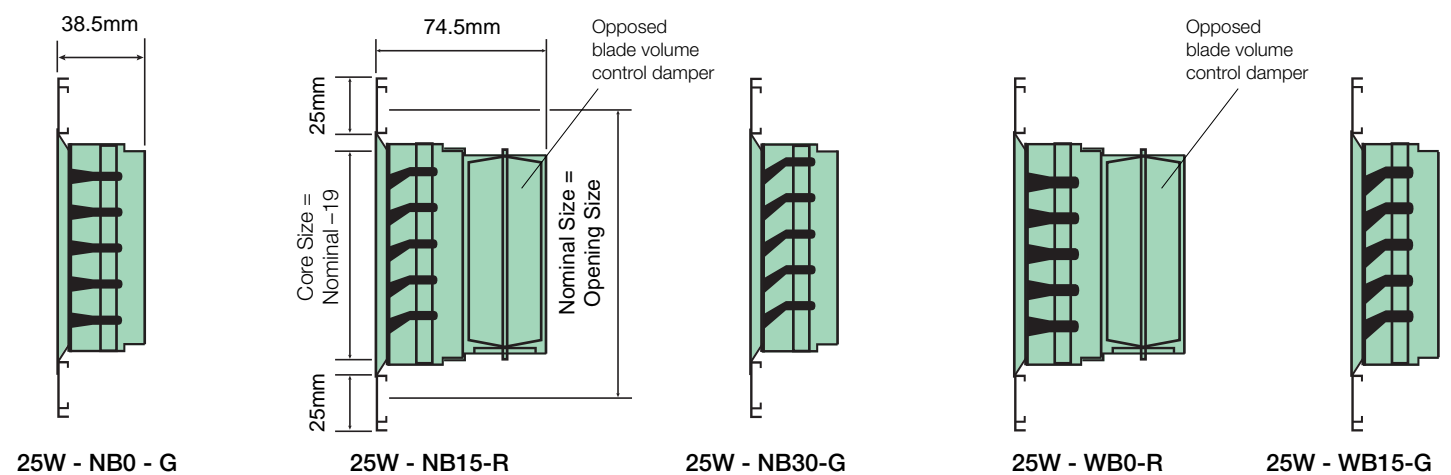
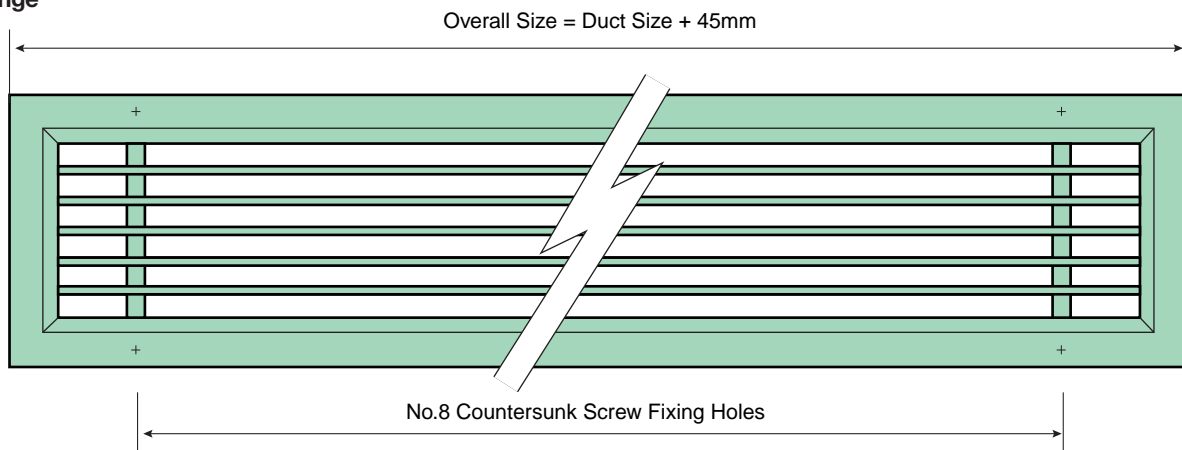

Dimensions Models NB and WB

32mm Flange

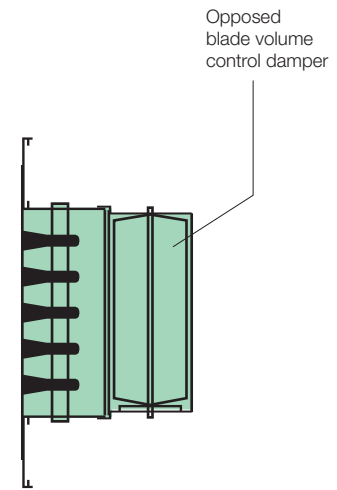
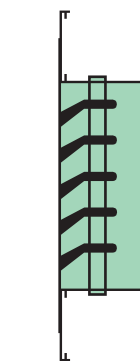
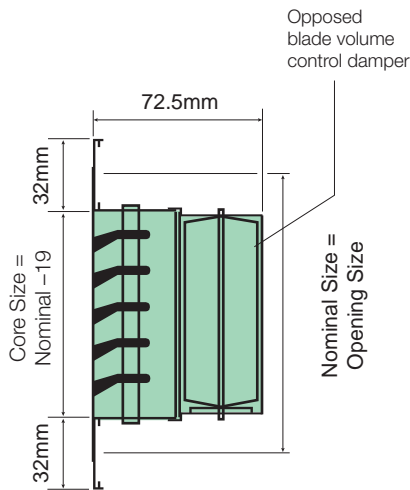
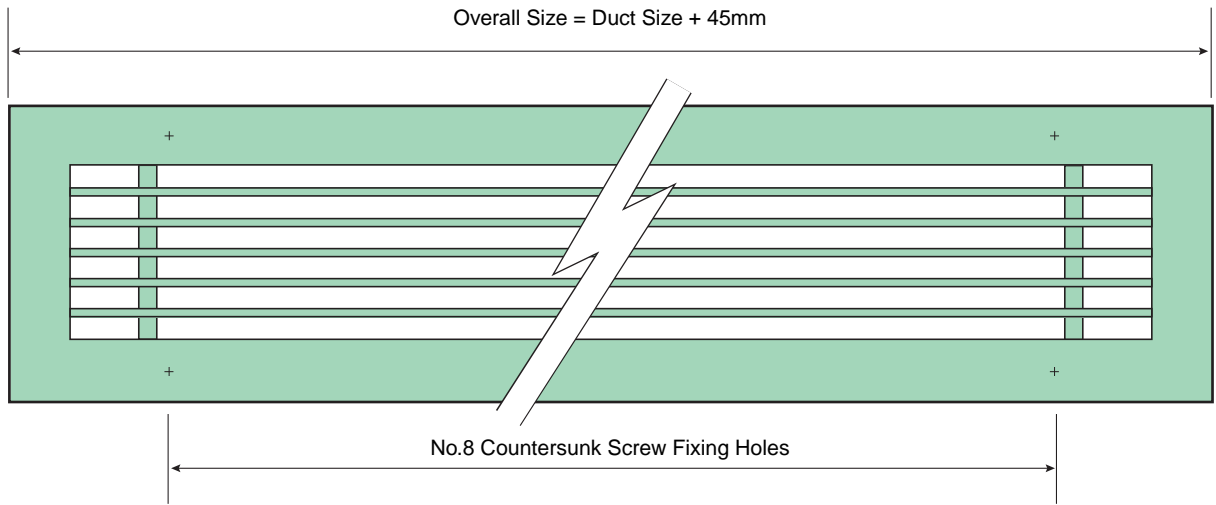

32W - NB0 - G

32W- NB15-R

32W - NB30-G

32W - WB0-G

32W - WB15-G

All Grilles are supplied Duct Size unless otherwise stated. If overall dimensions are critical, these must be stated on order.

Core Only

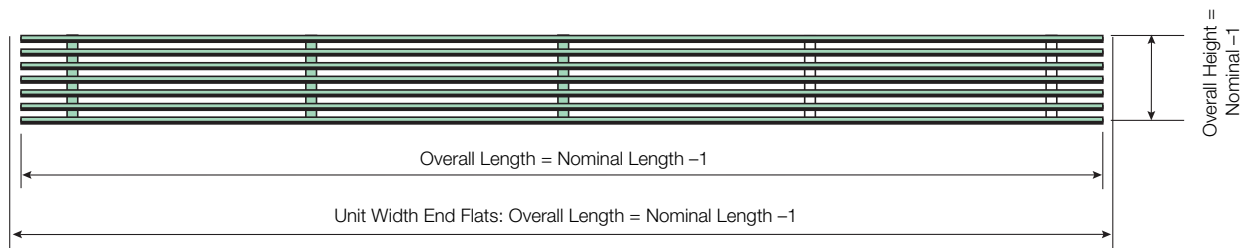

Cores can be supplied with Secret Strap Fixings Type F4 or F6 if required.

Models GNO and GWO Specifications

Specifications

Materials

Extruded aluminium throughout, with tube spacers on rods fixed through frame.

Construction

Frames are mitred and can be joined either by argon-arc welding or mechanical cleating.

Finish

Standard finish is baked enamel silver RAL 9006 or our standard white RAL 9010. An extensive range of coloured finishes is available including anodising on mechanical cleated grilles.

Fixings

Standard

Countersunk face fixing holes for screw fixing.

Optional

Concealed bracket or spring clips.

See Fixing Details for further information.

Sizes Available

100 x 100 to 1200 x 1200, 1800 & continuous in 25mm increments. Special sizes are available.

Mullions

Tube mullions are at approximately 300mm centres. These grilles can be manufactured as long multi-part units to give continuous appearance.

Dampers

Opposed blade dampers can be fitted for volume balancing. Damper operation is by concealed screw cam.

Ordering

Sizes are assumed to be nominal width x height unless otherwise indicated on your order.

Nominal sizes allow fitting tolerance to opening or duct of that size.

Please refer to the ordering Information and Dimensions.

Models Available

GNO

Fixed 3.5mm blade linear grille having blades at 0° deflection.

GN15

Fixed 3.5mm blade linear grille having blades at 15° deflection.

NB30

Fixed 3.5mm blade linear grille having blades at 30° deflection.

GWO

Fixed 6.5mm blade linear grille having blades at 0° deflection.

GW15

Fixed 6.5mm blade linear grille having blades at 15° deflection.

G

Grille Only.

R

Grille with Opposed Blade Damper.

Special Applications

A set of adjustable vertical blades can be fitted behind the grille core to provide a wider angle discharge.

For details please refer to Sales Office.

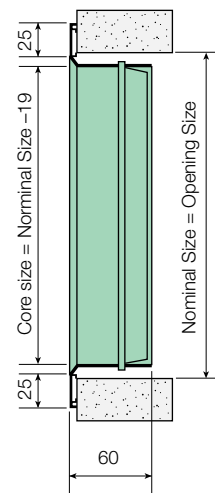

Models GNO and GWO Selection Procedure

Selection Procedure

1. Determine air volume flow rate per outlet.
2. If GNO or GWO supply application, establish available throw.
3. Establish require maximum noise and pressure values - refer to the appropriate nomogram
4. With a straight edge line across from the litres per second value through values within the maximum parameters established to the pivot line.
5. Retaining the position of intersection at the pivot line, pivot the straight edge until it meets acceptable values of size to its left and right.

Note:

The pivot line represents an area and by maintaining position on this line widths and heights can be selected of equal area. See note regarding effect of aspect ratio on throw for supply applications. Please refer to additional note on Page 1 regarding air jet characteristics under various conditions.

Notes to Selection Data

Pressure Loss

The total pressure losses given are for grilles with dampers fitted with the dampers fully open. A 10% reduction of the value can be taken for grilles without dampers.

Sound Levels

Wherever possible we give NR power levels generated by the product. This enables the allowances for room characteristics, surface mounting and multiple outlets from the sound advice leaflet to be taken into account and more accurately predict the sound pressure measured in the occupied space.

The NR power level given includes for a fully open damper. For grilles without dampers 2db can be subtracted. However, the effect of partly closing the damper for balancing purposes can add significantly to generated noise.

Throw

Throws shown in the catalogue are based on horizontal discharge of cooled air with full attachment of the jet to a flat ceiling close enough above the grille position to enable this condition to occur. For most cases for ceiling effect the grille would be positioned no more than 300mm below the ceiling.

Core area (m²) - Preferred Sizes

Nominal Height	Nominal Width - mm													
	mm	150	200	250	300	350	400	500	600	700	800	900	1000	1100
100	.0077	.0110	.0143	.0176	.0209	.0242	.0308	.0374	.0440	.0506	.0572	.0638	.0704	.0770
150	.0136	.0193	.0251	.0309	.0367	.0425	.0541	.0657	.0773	.0889	.1005	.1121	.1237	.1353
200		.0276	.0359	.0442	.0525	.0608	.0774	.0940	.1106	.1272	.1438	.1604	.1770	.1936
250			.0467	.0574	.0683	.0791	.1007	.1223	.1439	.1655	.1871	.2087	.2303	.2519
300				.0708	.0841	.0974	.1240	.1506	.1772	.2038	.2304	.2570	.2836	.3102
400						.1340	.1706	.2072	.2438	.2804	.3170	.3536	.3902	.4268
500							.2172	.2638	.3104	.3570	.4036	.4502	.4968	.5434
600								.3204	.3770	.4336	.4902	.5468	.6034	.6600

Free Area Factors:

GNO = 0.85

GWO = 0.70

Based on 300 x 300 nominal size, the figures above may vary by 5% dependent on grille size.

Model GNO and GWO Selection Nomogram

GWO Correction Factors		
Sound Power Levels	Pressure Levels	Throw
+5db	+20%	+20%

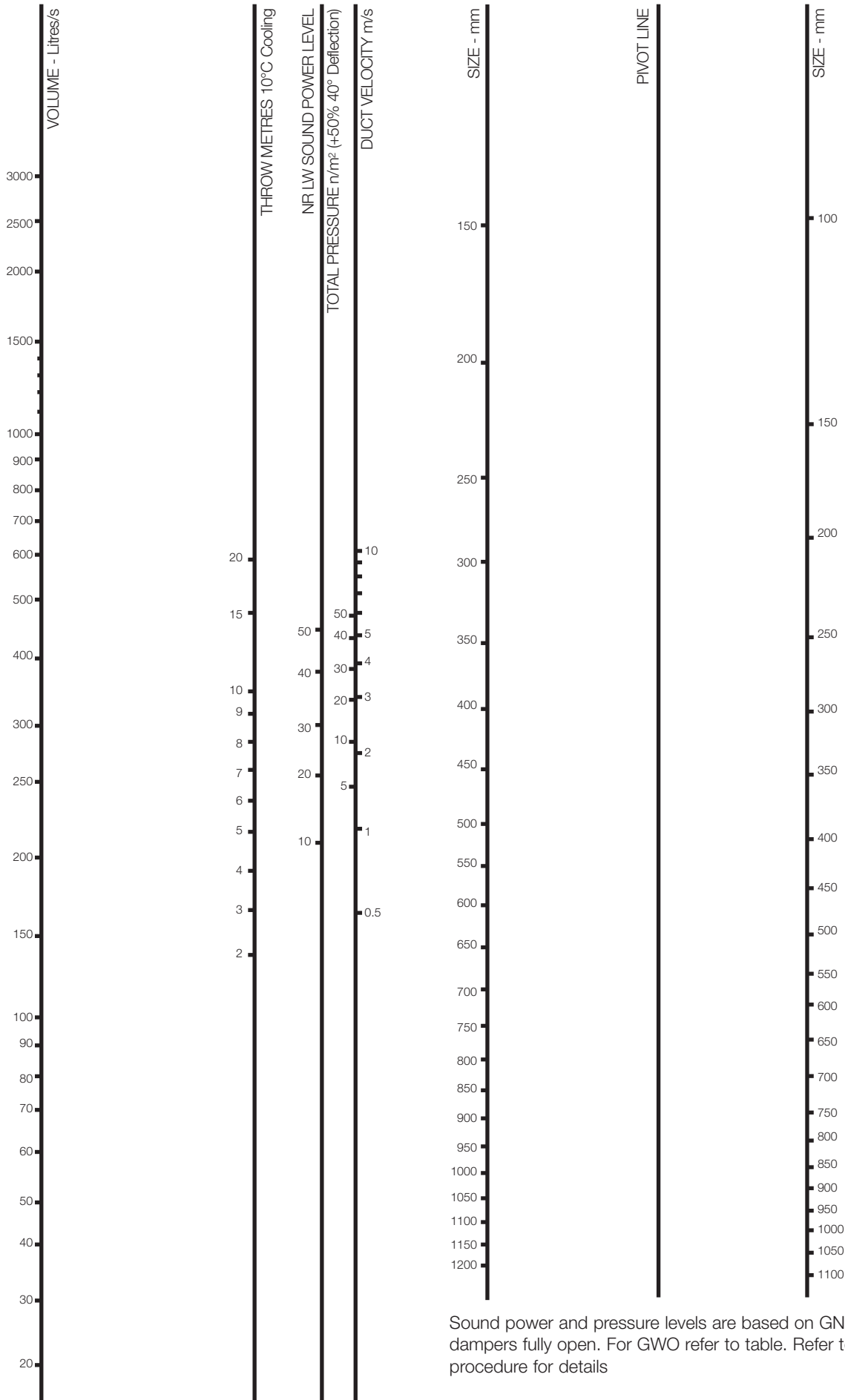

Sound power and pressure levels are based on GNO with dampers fully open. For GWO refer to table. Refer to selection procedure for details

Models GNO and GWO Dimensions

Dimensions

Model GNOR

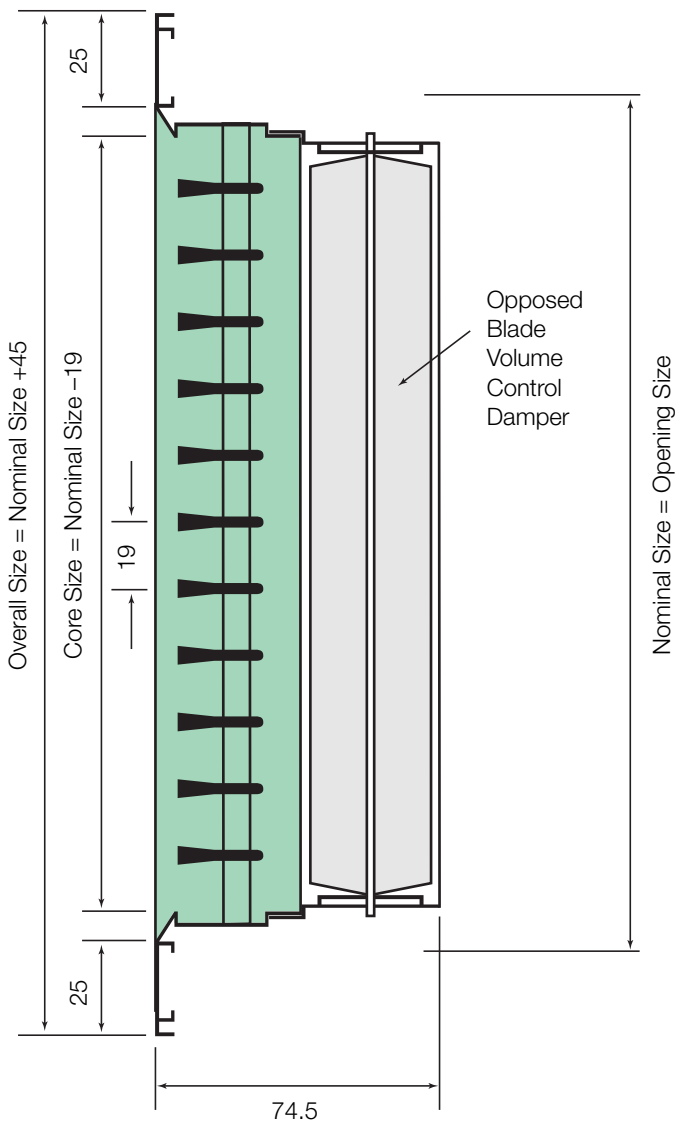

Model GNOG

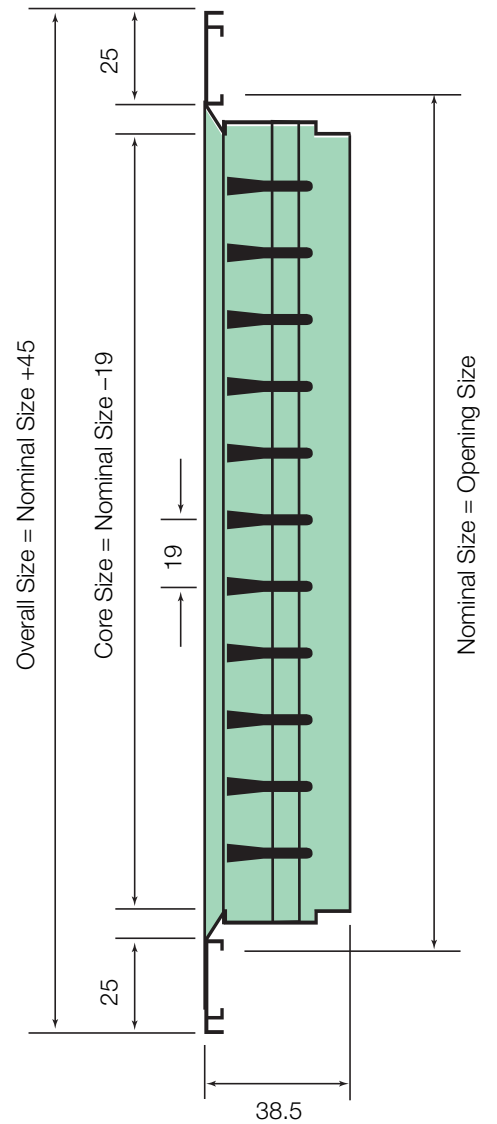

Installation Guide

Type F1 Screw Fixing

Standard face countersunk holes for screw fixing.

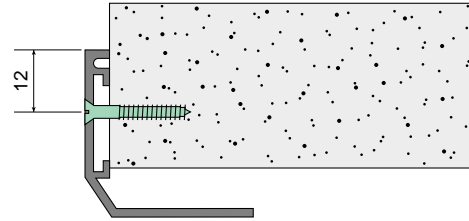

Type F2 Spring Clip Fixing

Optional spring clips.

Note:

For satisfactory fixing require accurately formed opening or duct with firm sides. Not suitable for ceiling or high sidewall installation.

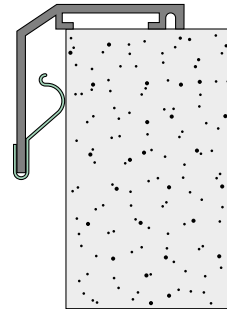

Type F4 Secret Strap Fixing

Optional rear strap.

Note:

Mating strap by others.

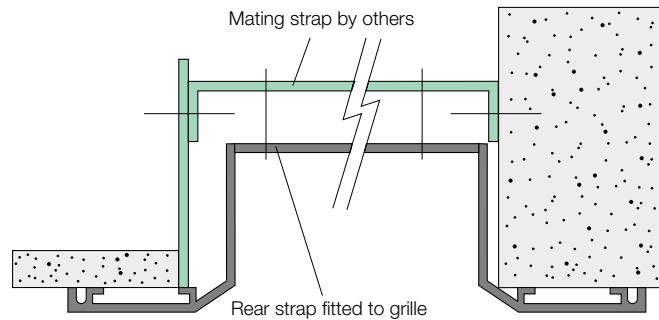

Type F6 Secret strap and 'U' Bracket Fixing

Optional rear strap plus mating 'U' bracket.

Note:

Hemmed duct by others or plenums by us.

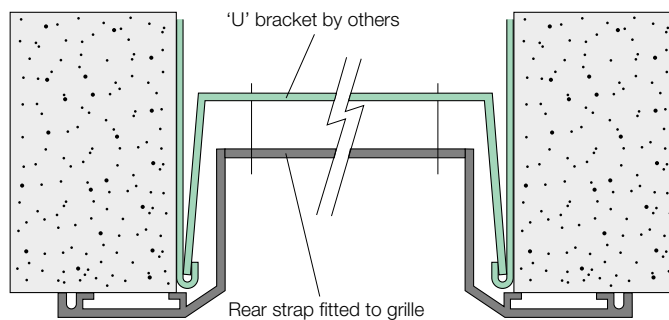

Type F8 - Ceiling Alignment Clip

(Details of ceiling system and clip to be supplied).

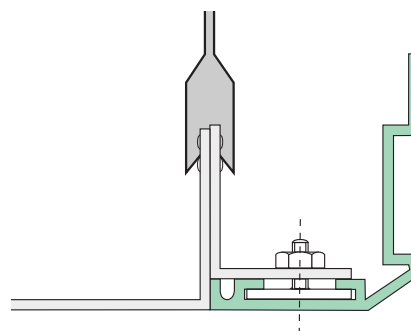

Removable Core Details

Spring Mullion Arrangement Suitable for use with Models NB, GN, WB and GW

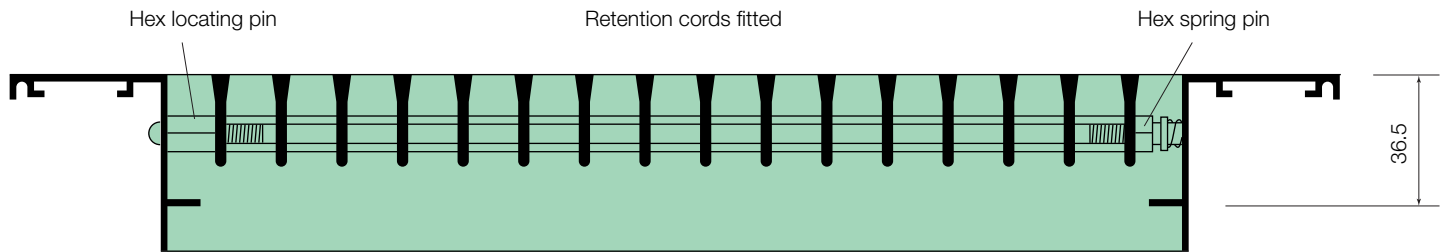

Model 32W - GN0G - RC

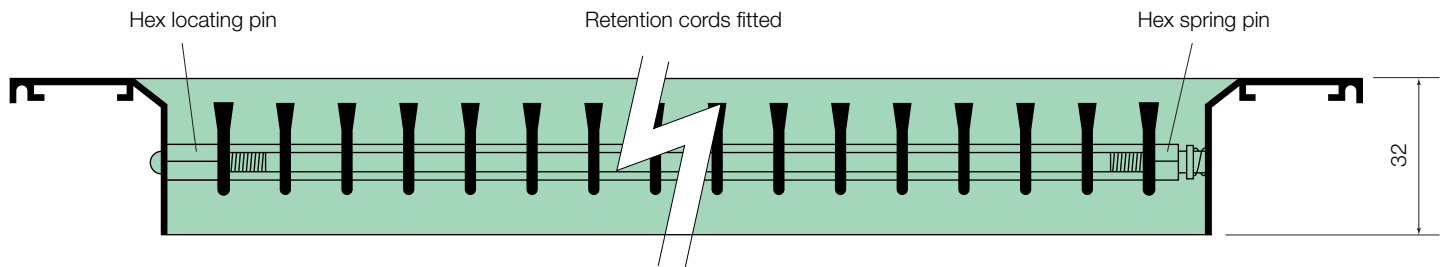

Model 25W - GN0G - RC

Removable Core Details

Brass Ferrule Arrangements. Suitable for use with models NB, GN, WB and GW.

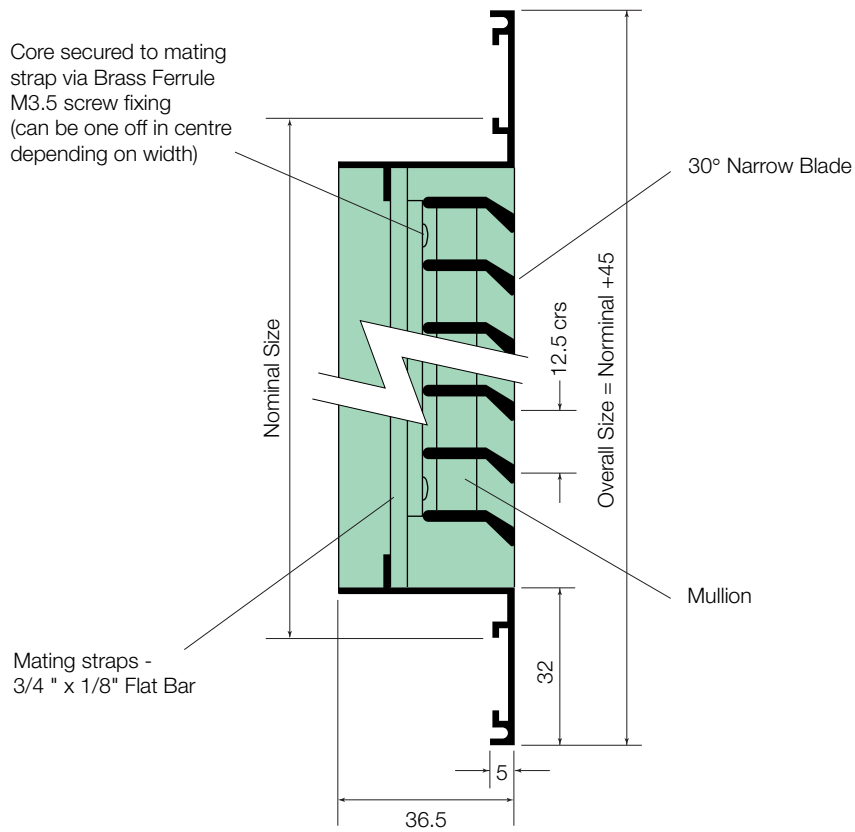

Model 32W - NB30G - RC

Type F9 - Removable Core Screw Fix

Type F10 - Removable Core Sprung Mullion

Screw through strap on core into strap on outer flange

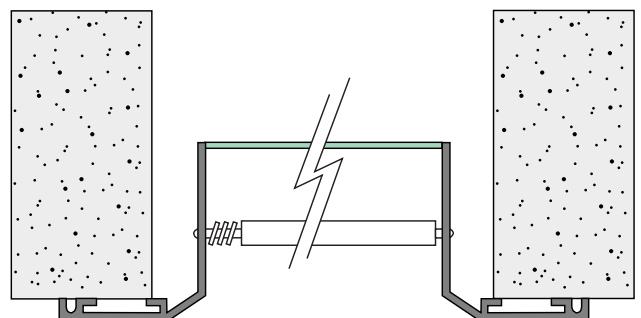
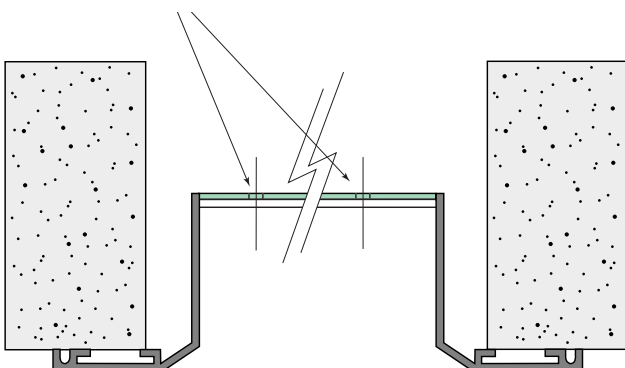

Ordering Information – Linear Bar

To order a cleated 25mm Flange Narrow Blade Fixed Core 15 Degree Blade with no fixing holes, finished RAL9010 white. This model would normally be written as: 25C - NB15 - R - FC - F0 - 3

Example

Flange Style	Model Type	Damper	Core	Fixing	Finish
25C	NB15	R	FC	F0	3
20C 20mm flange with mechanically cleated corners		R Registers (grille with dampers) G Grille only			0 Mill extruded aluminium 1 Natural anodised aluminium frame (only available with mechanically cleated corners)
20W 20mm flange with fully welded corners			RC Removable Core FC Fixed Core		2 Silver RAL 9006 stove enamel finish
25C 25mm flange with mechanically cleated corners	NB0 Fixed Blade Linear with 3.5mm Blade 0° deflection and 12.5mm pitch			F0 No fixing (e.g. for 'lay-in' fixing or where fixing holes are drilled on site)	3 White RAL 9010 (20% gloss) stove enamel finish
25W 25mm flange with fully welded corners	NB15 Fixed Blade Linear with 3.5mm Blade 15° deflection and 12.5mm pitch			F1 Countersunk screw fixing holes in flanges	4 Black eggshell finish
32C 32mm flange with mechanically cleated corners	NB30 Fixed Blade Linear with 3.5mm Blade 30° deflection and 12.5mm pitch			F2 Spring Clip - for friction fitting to accurate prepared openings (not suitable for ceilings)	5 Brushed (linished) natural aluminium face surfaces (32C or 32W flange only)
32W 32mm flange with fully welded corners	WB0 Fixed Blade Linear with 6.5mm Blade 0° deflection and 12.5mm pitch			F4 Secret Strap - mating strap in duct or opening provided by others	6 Special finish to be specified external to the model reference
27BW 27mm wide bevel edge flange.	WB15 Fixed Blade Linear with 6.5mm Blade 15° deflection and 12.5mm pitch			F6 'U' bracket fixing with mating strap fitted to grille.	Where more than one special finish is required, consecutive numbers above 6 are used with an explanatory key
25TW8 28mm stepped flange to suit 8mm 'tegaral' style ceiling grid.	GN0 Fixed Blade 0° Narrow Blade Grille with 19mm pitch			F8 Ceiling clip (detail to be supplied, i.e., type of ceiling, spring tee)	
RAI Reversed angle flange internal	GN15 Fixed Blade 15° Narrow Blade Grille with 19mm pitch			F9 Removable core - Screw fix	
RAE Reversed angle flange external	GN30 Fixed Blade 30° Narrow Blade Grille with 19mm pitch			F10 Removable core - Sprung mullion	
	GW0 Fixed Blade 0° Wide Blade Grille with 19mm pitch				
	GW15 Fixed Blade 15° Wide Blade Grille with 19mm pitch				

Note: Special applications for grilles with rear set of vanes please refer to page 7 or 12.

Important Note: If the overall size is critical then it must be clearly stated on the order. All orders must be addressed to AIR DIFFUSION, Ruskin Air Management Limited.

Note: Redesign may occur which supersedes the information in this brochure.

Plenum Boxes

Plenum Boxes

Supplied unlined as standard with side entry spigot. Grilles are attached by either pop rivet or PK screw through neck of grille.

Plenum boxes can be supplied internally lined with 12mm class "O" foam at extra cost. Apply to sales office for price.

Specifications

Material

Standard is a minimum of 0.7mm thick galvanised or zinc coated steel.

Construction

Plenum boxes are generally fabricated in 3 sections having tray ends, which are either mechanically joined or spot welded to form an airtight seal. Flush ends (no tray indents) are also available. As standard, spigots are side entry and located centrally. All boxes are supplied with plain edges, as standard, (FO fixing).

Standard Installation Method

The tray ends of the plenum box incorporate a 15mm indent, on each side to allow for 8mm drop rod fixings, which gives space for holes to be drilled (by others) without disturbing the active section.

Installation Options

Fixing lugs can be factory fitted if preferred or special fixing methods (by

others) may be used.

For plenum boxes having flush ends separate hanging brackets/fixing lugs need to be fitted to allow independent support of diffuser and plenum box.

Accessories

Joggled style plenum boxes or pan adapters.

Spigot dampers include; quadrant, teleflex operation or cord operated.

12mm thick Class 'O' internal lining.

Equalising grids (50% free area perforated mesh).

Turning Vanes.

Fixing lugs or special fixings (by others).

Flush Ends (No Indent).

Finish

Self finish galvanised or zinc coated steel as standard.

Black paint can be applied to internal faces if required.

Pressure Drops and Sound Rating

The pressure drop given is for supply grille with damper fully open. When the grille is installed with plenum box, the pressure loss of the box has to be added to the grille.

	Spigot Velocity m/s					
	1.5	2.0	2.5	3.0	3.5	4.0
Pressure Drop Pa*	2	4	6	8	12	16
Sound Power Level NR*	-	-	25	30	35	40

* The figures given are approximate - dependent upon spigot entry conditions

Plenum Box Spigot Volumes (l/s)

Diameter (mm)	Spigot Velocity m/s					
	1.5	2.0	2.5	3.0	3.5	4.0
100	10	15	19	22	26	30
125	18	24	30	35	41	47
150	25	34	42	51	60	68
175	35	46	58	70	82	94
200	45	60	75	91	109	121
225	58	77	96	117	137	151
250	71	95	120	142	170	191
275	86	115	145	172	205	230
300	103	139	172	208	240	275
325	120	160	200	240	280	320
350	140	188	235	280	328	375
400	185	245	310	370	430	495

Plenum Box Dimensions

Type PBL-1

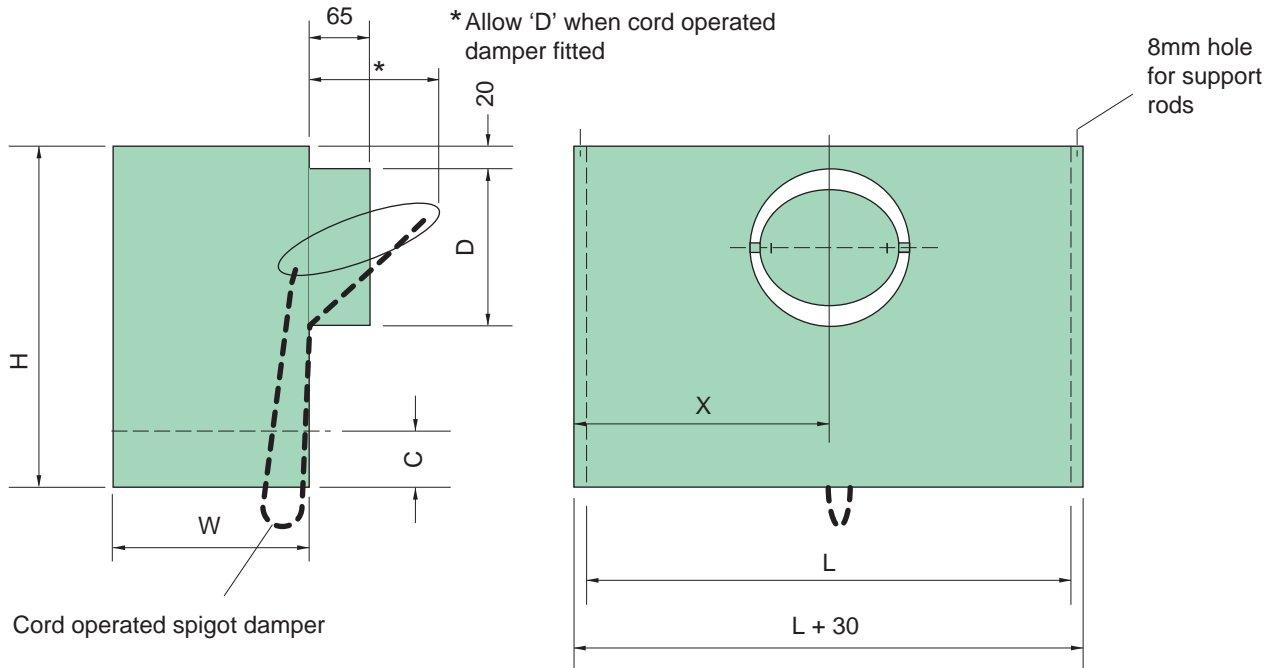

Order Detail

H	L	W	D	C		X
				LH	RH	
-	-	-	-	-	-	-

Angle Bracket fixing available if required.

Type PBL-1 for F6 fixing

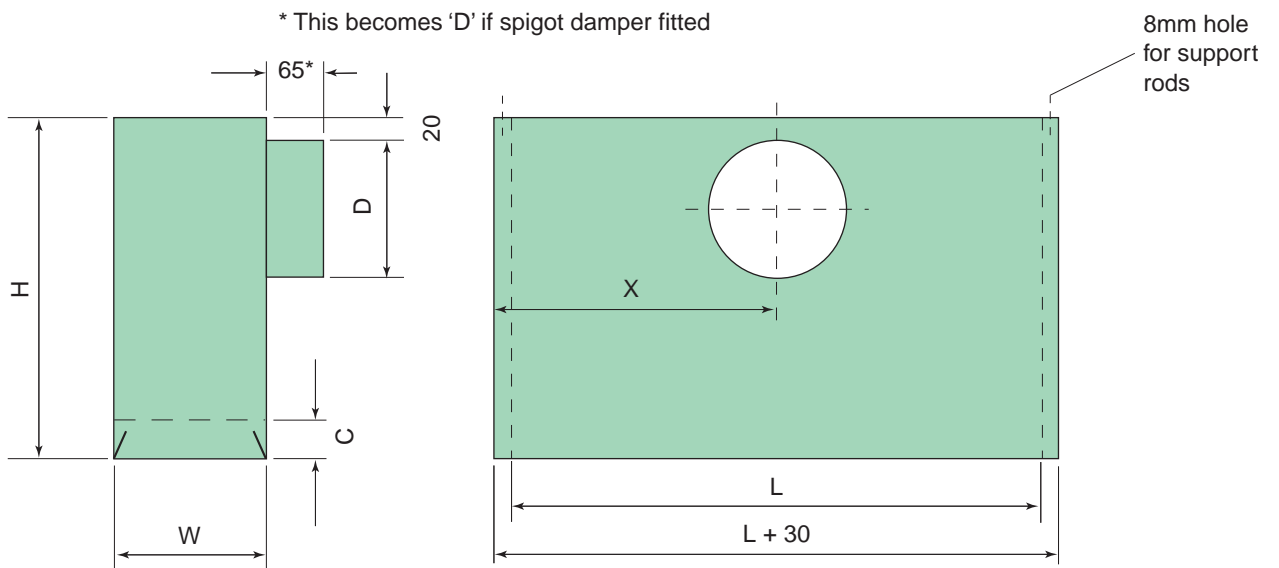

Order Detail

H	L	W	D	C		X
				LH	RH	
-	-	-	-	-	-	-

Boxes shown with Indented Ends.
Plain End boxes also available.

Plenum Box Dimensions Continued

Manual Quadrant Control Damper

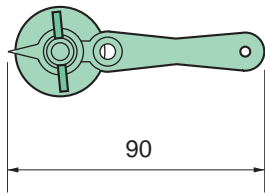

Manual Quadrant Control
(complete with damper blade position label).

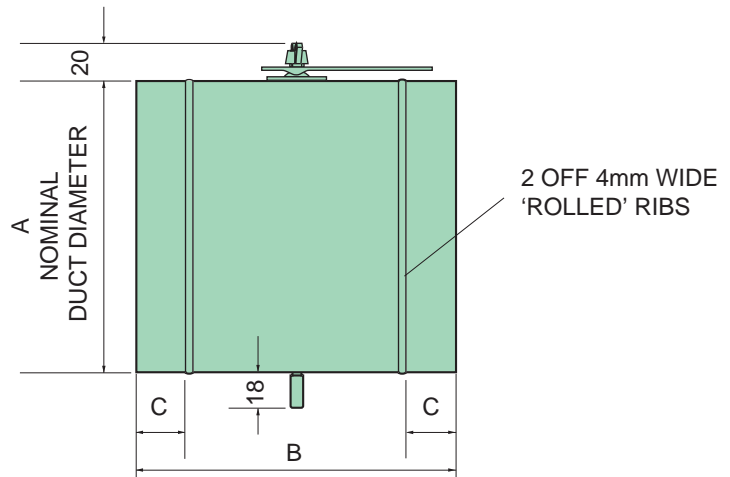

Model ref	A Nom Sizes (mm)	B Case Depth	C
Q	100	170	26
Q	125	170	26
Q	150	170	26
Q	160	170	26
Q	200	260	26
Q	250	260	26
Q	300	325	35
Q	315	325	35

Ordering Information – Plenum Boxes

Example

Model PBL-1	Internal Lining U	Spigot Damper N	Options 0	Dimensions
Plenum Boxes	U – Standard Unlined Plenum Box	N – Plain spigot no damper	0 – No options	See example below
PBL-1 Linear Plenum Box with either a circular or square side entry spigot	L – 12mm Class 'O' Internal Lining.	Q – Quadrant damper.	1 – Internal faces painted black.	
PBL-2 Linear Plenum Box having either a circular or square top entry spigot		T – Teleflex damper fitted to spigot.	2 – Equalising grid.	
PBL-3 Linear Plenum Box with joggle section having either a circular or square side entry spigot		C – Cord operated damper fitted to spigot.	3 – Fixing lugs fitted to side of plenum.	
			4 – Profile ends on each end of plenum.	
			5 – Hemmed Edge for secret strap fixing.	

Dimensions PBL - 1, PBS - 2, Example

Neck Size	Plenum Height	Circular Spigot Diameter	OR	(Sq. / Rect. Spigot Width x Height)	Centre Line of Spigot
L x W	H	∅D		C x E	G
450 x 450	350	250		0	0

'0' Denotes Standard.

Important Note: All orders must be addressed to AIR DIFFUSION, Ruskin Air Management Limited.

Product Range

- Swirl Diffusers
- Displacement Ventilation Diffusers
- Perforated and Louvre Face Ceiling Diffusers
- High Induction Slot Diffusers
- Slot and Fixed Blade Linear Diffusers
- Cylinder and Jet Nozzle Diffusers
- Circular Diffusers and Air Valves
- Floor Grilles
- Linear Bar Grilles
- Wall and Ceiling Grilles
- External Louvres
- Chilled Beam Panels
- Systempac
- Miscellaneous

Slot and Fixed Blade Diffusers



Swirl Diffusers



Wall and Ceiling Grilles



Chilled Beam Panels



**Ruskin Air Management Limited
is a BS EN ISO 9000 registered
company.**

The statements made in this brochure or by our representatives in consequence of any enquiries arising out of this document are given for information purposes only. They are not intended to have any legal effect and the company is not to be regarded as bound thereby. The company will only accept obligations which are expressly negotiated for and agreed and incorporated into a written agreement made with its customers.

Due to a policy of continuous product development the specification and details contained herein are subject to alteration without prior notice.

**Comprehensive and detailed information
is available for all Air Diffusion products.
Visit our website at www.air-diffusion.co.uk**

Ruskin Air Management Limited



Stourbridge Road, Bridgnorth, Shropshire,
WV15 5BB England.
Tel: 01746 761921
Fax: 01746 760127
Email: sales@air-diffusion.co.uk
Website: www.air-diffusion.co.uk

Air Diffusion

Grilles Diffusers Louvres Chilled Beams